



# **ALLEGRA X-12/R, X-15R**

## **Service Manual**

Beckman Coulter, Inc. • 250 S. Kraemer Blvd. • Brea, California 92821  
Sales and Service: 1-800-742-2345 • Internet: [www.beckmancoulter.com](http://www.beckmancoulter.com)

## **COPYRIGHT INFORMATION**

This Service Manual is copyrighted and Beckman Coulter reserves all rights. This document may not, in whole or part, be copied, photocopied, reproduced, translated, or reduced to any electronic medium or machine-readable form without prior consent, in writing, from Beckman Coulter, Inc.

## **RELATED DOCUMENTS**

This service Manual does not include the Operator's Manual for this instrument. The Operator's Manual contains instructions for proper operation of the instrument, information regarding the limitations, specifications, precautions and hazards associated with its use.

To obtain a copy of the Operator's Manual(s), please order it through any Beckman Coulter Sales and Service Office.

<b><u>Part Number</u></b>	<b><u>Description</u></b>
GX-IM-1	Allegra X-12/R Instruction Manual
GXR-IM-1	Allegra X-15R Instruction Manual

## **SAFETY REMINDERS**

The following pages summarize cautionary information basic to the safe operation of this instrument. However, it is strongly recommended that the user read the entire manual carefully before attempting to service the instrument. In addition, be sure to heed all **NOTES**, **CAUTIONS**, and **WARNINGS**, which are specifically defined as follows:



**NOTE:** Used to make a procedure easier or clearer. To disregard it may cause inconvenience, but not mechanical damage or personal injury.

**CAUTION:** Used to prevent equipment damage. To disregard the caution may cause mechanical damage, however, personal injury is not likely.

**WARNING:** Used whenever an action or circumstance may potentially cause personal injury or loss of life. Mechanical damage may also result.

### **Specified Warnings:**

**WARNING:** The use of parts not designed or documented for this product is not authorized. The use of non-Beckman Coulter parts may cause damage to the product or personal injury to operating personnel. The use of these parts will also void any warranty.

**WARNING:** The bolts for the anchoring bracket are critical and classified as Class 10. Only those bolts are allowed to use.

## **IMPORTANT NOTICE**

This Service Manual is designed solely for the use of Beckman Coulter Field Service Representatives who have had training and experience in the servicing of Beckman Coulter products. To improve product performance, Beckman Coulter may have made changes in the product to which this Service Manual relates. Such changes may not be reflected in this manual. Accordingly, Beckman Coulter makes no representation or warranty, either express or implied, that the information contained in this Service Manual is complete or accurate with respect to the particular product to which this manual pertains, and the purchaser must assume all risks in the use of this manual for the purpose of performing service upon such product.

**Because of the possible hazards involved to an inexperienced person in servicing the product, Beckman Coulter recommends that servicing of your product be performed only by Beckman Coulter Field Service Representatives.**

**Do not replace any centrifuge components with parts not specified for use on this instrument.**

Components of this instrument which are considered user serviceable are discussed in detail in the instrument's instruction manual.

### **CAUTION:**

**The use of parts not designed or documented for this product is not authorized. The use of non-Beckman Coulter parts may cause damage to the product or personal injury to operating personnel. The use of these parts will also void any warranty.**

### **WARNING:**

**The bolts for the anchoring bracket are critical and classified as Class 10. Only those bolts are allowed to use.**

## MECHANICAL SAFETY

Good mechanical safety practices are more important than ever now that microprocessors are taking control of mechanical devices. Yet, the area of mechanical safety is often overlooked during instrument servicing. We may be able to change this situation if you heed the following safety tips:

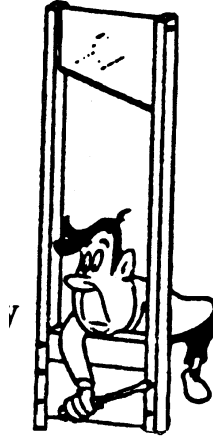

1. Remember to keep clothing and fingers away from rotating or moving components. It is easy to slip, lose a tie, or get cut while working near one of these devices.
2. Unless it is absolutely essential, never run mechanical components without the protective guards in place.
3. Always use the tools specifically recommended for the job. This not only reduces the chances of injury, it minimizes damage to the instrument.
4. Although not always possible, it is recommended that mechanical devices be adjusted or calibrated with the power turned OFF. This is especially important if you are working with a microprocessor-controlled instrument, which can start running without notice or user intervention.
5. After the mechanical repairs have been completed, always check that all mounting hardware and safety shields are in place and secure. By doing so, you will not only ensure safe operation of the instrument, but may reduce callbacks.

As you can appreciate, all it takes is good common sense, plus good safety techniques that are basic and easy to remember. With this in mind, you should have no trouble servicing mechanical devices safely.

## ELECTRICAL SAFETY

It is shocking but true. Many people service instruments without giving much thought to electrical safety. Unfortunately, this can be a dangerous mistake.



It pays to take a few precautions before and during servicing to avoid injury from electrical shock. Here are a few safety tips that can help keep you on the job without a sudden vacation:

1. Avoid standing on damp floors! People have been shocked simply by standing on a wet floor and then working on live equipment.
2. Be sure to disconnect the power cord before working on any high voltage circuitry! As power switches disappear from new equipment, this precaution is very easy to overlook. Attach probes for checking voltage and current with power off!
3. Read and heed **ALL** caution labels! They are posted for **YOUR** safety.
4. Take care of test equipment. Be sure to use the right probes for the right job. Measuring high voltages, for example, requires a well-insulated, high voltage probe. Damaged probes and cables are dangerous and should not be used. Also, be cautious around test equipment such as an oscilloscope. The oscilloscope case may become live if you connect the cable ground to a live circuit. Avoid this dangerous situation at all times!
5. Always treat cathode ray tubes (CRTs) and uncased photomultiplier tubes (PMTs) with special care. When carrying them, wear eyeglasses and protective gloves. If these devices are dropped or struck with a sharp object, they can implode violently and scatter glass.

These basic tips regarding good electrical safety practices are easy to remember. Combined with good common sense, they should keep you on the job for a long time to come.

## **ELECTROSTATIC DISCHARGE**

Static electricity is an electrical charge which can damage circuitry and components.

Listed below are important Electrostatic Discharge guidelines for handling electronic components. Following these guidelines will avoid needless damage to circuit cards and components on them.

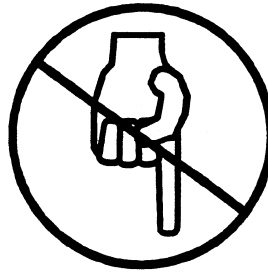

- Keep paper, non-conductive plastic, plastic foams or cardboard away from circuit boards and components and static-free work areas.
- Keep hand creams and food away from the conductive work surfaces. If spilled on the bench top, these materials contaminate and increase the resistivity of the work area.
- Be especially careful when using soldering guns around conductive work surfaces. Solder spills and heat from the gun may melt and damage the conductive mat.
- Check the grounding connections on wrist strap and static mats. (Mat must have proper ground.) Make certain they fit snugly before starting work with the components and printed circuit cards.
- Touch the conductive work surfaces before starting work.
- Know the ESD caution symbols.
- Do not allow anyone not grounded to touch ESD sensitive components in the work area. To be grounded, they must be standing on the conductive floor mat and must touch the conductive bench top mat before touching the components or printed circuit cards.
- Do not place ESD-sensitive components on work areas that are not grounded properly.
- Do not touch the component by the pins or leads since the most damage is done at these points by ESD. Handle the components by the cap edges or body and the printed circuit cards by the edges.
- Do not handle components or printed circuit cards during transport between work stations. Components or cards must not be directly handled by anyone not grounded.
- Do not use Refrigerant or other chlorinated cleaners at the work area. Use conductive or anti-static bags and containers for storage and transportation of components or circuit boards.



## **HIGH VOLTAGE REMINDER**

When you have removed the front panel and/or the rear panel from the instrument and have the circuit breaker on, there is high voltage (>200VAC/ 300VDC) on some components. This voltage is there even though the instrument is not running.

## **REFRIGERATION SYSTEM SAFETY**

Working with refrigeration systems requires special equipment and training. If you are not familiar with the operational theory for refrigeration systems and the special requirements for performing service on a system, do **NOT** attempt it. Use the following precautions for working with refrigeration systems in Beckman instruments.

1. Always use protective glasses and clothing.
2. Do **NOT** inhale refrigerant. It has an intoxicating effect and is harmful to your health.
3. Refrigerant can easily cause "frostbite". Be especially careful with liquid refrigerant.
4. Use caution when replacing a burnt out compressor. The oil in the compressor may be very caustic or acidic. Use protective gloves.
5. Charge refrigeration systems with gas from the low side only. High side charging may damage the compressor.
6. Do **NOT** run a compressor without refrigerant in the system. Compressors are cooled by the refrigerant and will burn out if there is no cooling.

## **BRAZING SAFETY PRECAUTIONS**

Brazing requires the use of a high-temperature "MAPP Gas" torch and as such many potential safety hazards exist. Always follow the guidelines below when brazing.

1. Wear safety glasses.
2. Work in a ventilated area.
3. Know fire extinguisher location.
4. Heat sink, shield components.
5. All refrigerant removed from the system (no pressure).
6. Do not invert turbo-torch (flame-thrower).
7. Fit and brace parts.
8. Check to see if smoke detectors are present--move your operation.
9. Always insure that heated parts have cooled completely before handling them.

# **ALLEGRA X12 &12R, X-15R**

## Main Table of Contents

<b><u>INTRODUCTION</u></b>	<b><u>1 - 1</u></b>
<b><u>SYSTEM INSTALLATION</u></b>	<b><u>2 - 1</u></b>
<b><u>SERVICE PROCEDURES</u></b>	<b><u>3 - 1</u></b>
<b><u>SCHEMATICS</u></b>	<b><u>4 - 1</u></b>
<b><u>PARTS</u></b>	<b><u>5 - 1</u></b>
<b><u>ACCESSORIES &amp; MISCELLANEOUS</u></b>	<b><u>6 - 1</u></b>
<b><u>APPLICATIONS</u></b>	<b><u>7 - 1</u></b>
<b><u>SERVICE MEMOS</u></b>	<b><u>8 - 1</u></b>

**SECTION 1**

**INTRODUCTION**

<b>1.1 ALLEGRA X-12/R, X-15R PERFORMANCE SPECIFICATION</b>	<b>1 - 1</b>
<b>1.2 GENERAL DESCRIPTION</b>	<b>1 - 3</b>

## **SECTION 2**

### **SYSTEM INSTALLATION**

<b>2.1 SAFETY NOTICE</b>	<b>2 - 1</b>
<b>2.2 PREINSTALLATION REQUIREMENTS</b>	<b>2 - 3</b>
<b>2.3 CUSTOMER TRAINING</b>	<b>2 - 6</b>

## **SECTION 3**

### **SERVICE PROCEDURES**

<b>3.1 MECHANICAL SYSTEMS</b>	<b>3 - 1</b>
<b>3.2 TEMPERATURE CONTROL SYSTEM</b>	<b>3 - 8</b>
<b>3.3 TROUBLESHOOTING</b>	<b>3 - 15</b>
<b>3.4 PREVENTIVE MAINTENANCE</b>	<b>3 - 20</b>

## SECTION 4

### SCHEMATICS

<b>4.1 ALLEGRA X-12/R, X-15R CIRCUIT DESCRIPTION</b>	<b>4 - 1</b>
<b>4.2 SCHEMATICS X – 12/R</b>	<b>4 – 5</b>
<b>SCHEMATICS X – 15R</b>	<b>4 - 18</b>



## **SECTION 5**

### **PARTS**

<b>5.1 REPLACEMENT PARTS LIST</b>	<b>5 - 1</b>
<b>5.2 TABULATION DRAWING X-12/R</b>	<b>5 - 5</b>
<b>TABULATION DRAWING X-15R</b>	<b>5 - 13</b>

**SECTION 6**

**ACCESSORIES & MISCELLANEOUS**

**NO MATERIAL AVAILABLE AT THIS TIME**

**SECTION 7**

**APPLICATIONS**

**NO MATERIAL AVAILABLE AT THIS TIME**

**SECTION 8**

**SERVICE MEMOS**

**ISSUED DURING TRAINING CLASS**

## 1.1 Allegra X-12/R Specifications

*Only values with tolerances or limits are guaranteed data. Values without tolerances are informative data, without guarantee.*

### Speed

Set speed . . . . . 200 to 10 200 rpm in 10-rpm increments  
Speed display . . . . . actual rotor speed in 10-rpm increments

### Time

Set time . . . . . to 99 hours 59 minutes  
or continuous (hold)

### Time display

Timed run . . . . . indicates run time remaining  
Continuous (hold) or pulse run . . . . . indicates elapsed time

### Temperature

#### Set temperature

Allegra X-12R . . . . .  $-10$  to  $+40^{\circ}\text{C}$  in  $1^{\circ}$  increments  
Allegra X-12 . . . . . factory set at  $20^{\circ}\text{C}$

#### Temperature control (after equilibration)

Allegra X-12R . . . . .  $\pm 2^{\circ}\text{C}$  of set temperature\*  
Allegra X-12 . . . . .  $\pm 2^{\circ}\text{C}$  of the  $20^{\circ}\text{C}$  set temperature

Temperature display (after equilibration) . . . . . chamber temperature in  $1^{\circ}$  increments

Ambient temperature range . . . . .  $10$  to  $35^{\circ}\text{C}$

Ambient temperature range for optimum operation . . . . .  $10$  to  $25^{\circ}\text{C}$

Humidity restrictions . . . . .  $<75\%$  (noncondensing)

Acceleration . . . . . 10 acceleration profiles

Deceleration . . . . . 11 deceleration profiles

### Dimensions

Width . . . . . 76.2 cm (30.0 in.)  
Depth . . . . . 62.2 cm (24.5 in.)  
Height, door open . . . . . 96.5 cm (38.0 in.)  
Height, door closed . . . . . 34.3 cm (13.5 in.)  
Weight . . . . . 121 kg (267 lb)

Ventilation clearances (sides and rear) . . . . . 7.6 cm (3.0 in.)

### Finishes

Control panel . . . . . coated polycarbonate

Housing surfaces . . . . . acrylic baking enamel

### Electrical requirements

208-V, 60-Hz instrument . . . . . 187–229 VAC, 9 A, 60 Hz

200-V, 50/60-Hz instrument . . . . . 190–220 VAC, 10 A, 50/60 Hz

230-V, 50-Hz instrument . . . . . 207–253 VAC, 8 A, 50 Hz

### Maximum heat dissipation into room under

steady-state conditions . . . . . 4100Btu/hr (1.2kW)

Noise level 0.91 m (3 ft) in front of centrifuge . . . . .  $\leq 68$  dBa

Installation category . . . . . II

Pollution degree . . . . . 2

\* During transient conditions, such as acceleration and deceleration, rotor temperature may be outside this range. To reach temperatures above ambient, the centrifuge is dependent on the frictional heat generated inside the chamber during operation. At low run speeds or low ambient temperatures, the centrifuge may not be able to achieve some higher temperatures.

## 1.2 Allegra X-15R Specifications

*Only values with tolerances or limits are guaranteed data. Values without tolerances are informative data, without guarantee.*

### Speed

Set speed . . . . . 200 to 10 200 rpm in 10-rpm increments  
Speed display . . . . . actual rotor speed in 10-rpm increments

### Time

Set time . . . . . to 99 hours 59 minutes  
or continuous (hold)

### Time display

Timed run . . . . . indicates run time remaining  
Continuous (hold) or pulse run . . . . . indicates elapsed time

### Temperature

Set temperature . . . . . -10 to +40°C in 1° increments  
Temperature control (after equilibration) . . . . . ±2°C of set temperature\*

Temperature display (after equilibration) . . . . . chamber temperature in 1° increments

Ambient temperature range . . . . . 10 to 35°C

Ambient temperature range for optimum operation . . . . . 10 to 25°C

Humidity restrictions . . . . . <75% (noncondensing)

Acceleration . . . . . 10 acceleration profiles

Deceleration . . . . . 11 deceleration profiles

### Dimensions

Width . . . . . 76.2 cm (30.0 in.)

Depth . . . . . 62.2 cm (24.5 in.)

Height, door closed . . . . . 34.3 cm (13.5 in.)

Weight . . . . . 128 kg (283lb)

Ventilation clearances (sides and rear) . . . . . 7.6 cm (3.0 in.)

### Finishes

Control panel . . . . . coated polycarbonate

Housing surfaces . . . . . acrylic baking enamel

### Electrical requirements

208-V, 60-Hz instrument . . . . . 187–229 VAC, 12 A, 60 Hz

200-V, 50/60-Hz instrument . . . . . 190–220 VAC, 12 A, 50/60 Hz

230-V, 50-Hz instrument . . . . . 207–253 VAC, 12 A, 50 Hz

Maximum heat dissipation into room under

steady-state conditions . . . . . 6800 Btu/hr (2 kW)

Noise level 0.91 m (3 ft) in front of centrifuge . . . . . ≤68 dBa

Installation category . . . . . II

Pollution degree . . . . . 2

\* During transient conditions, such as acceleration and deceleration, rotor temperature may be outside this range. To reach temperatures above ambient, the centrifuge is dependent on the frictional heat generated inside the chamber during operation. At low run speeds or low ambient temperatures, the centrifuge may not be able to achieve some higher temperatures.

### 1.3 Allegra X-12/R, X-15R General Description

#### CENTRIFUGE FUNCTION

The Beckman Coulter Allegra X-12R, X-15R (refrigerated) or Allegra X-12 (constant controlled temperature) centrifuge (see Figure 1-1) is a benchtop centrifuge that generates centrifugal forces required for a wide variety of applications. Together with the Beckman Coulter rotors designed for use in this centrifuge, the centrifuge applications include:

- Routine processing such as sample preparations, pelleting, extractions, purifications, concentrations, phase separations, receptor binding, and column centrifugations.
- Cell isolation.
- Binding studies and separation of whole blood.
- Processing large numbers of small-volume samples in multiwell plates for concentrating tissue-culture cells, cloning and replicate studies, in-vitro cytotoxicity studies, receptor binding, and genetic engineering experimentation.
- Rapid sedimentation of protein precipitates, large particles, and cell debris.

The Allegra X-12/R and X-15R are microprocessor-controlled, providing interactive operation. The instrument design features a brushless asynchronous motor, automatic rotor identification system, program memory that enables repeated run conditions, temperature control system, and a choice of acceleration and deceleration rates.

User messages alert the operator to conditions that may need attention.

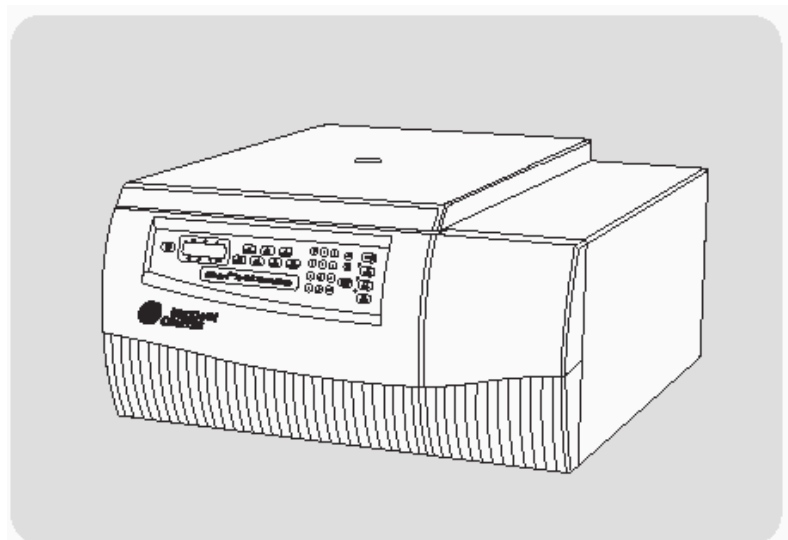
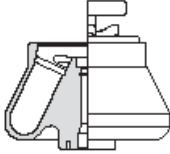
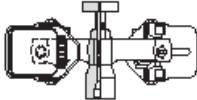
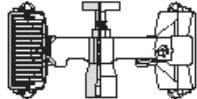
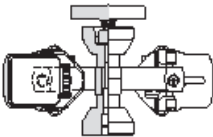

Figure 1-1. The Centrifuge

### Available Rotors

The following Beckman Coulter rotors can be used in the Allegra X-12 series centrifuge. The rotors are described in individual manuals that accompany each rotor.

Rotor Profile and Description	Rotor Selection Code	Max RPM*	Max RCF† (× g) at $r_{max}$	Number of Tubes × Nominal Capacity	Rotor Manual Number
FX6100 Fixed Angle  $r_{max} = 98.0 \text{ mm}$	FX6100	10 200	11 400	6 × 100 mL	GX-TB-005
SX4750 Swinging Bucket  Tube-and-bottle buckets, $r_{max} = 207.8 \text{ mm}$  Multiwell-plate carriers, $r_{max} = 183.2 \text{ mm}$	SX4750 SX4750μ	3 750 3 750	3 270 2 890	4 × 750 mL 4 × 96 mL	GX-TB-003
SX4750A Swinging Bucket (ARIES)  $r_{max} = 207.8 \text{ mm}$	SX4750A	3 750	3 270	4 × 750 mL	GX-TB-004

\* Maximum speeds are based on a solution density of 1.2 g/mL. At upper temperature and humidity ambient conditions, swinging bucket rotor speed may require reduction.

† Relative Centrifugal Field (RCF) is the ratio of the centrifugal acceleration at a specified radius and speed ( $r\omega^2$ ) to the standard acceleration of gravity ( $g$ ) according to the following formula:

$$RCF = \frac{r\omega^2}{g}$$



where  $r$  is the radius in millimeters,  $\omega$  is the angular velocity in radians per second ( $2\pi \text{ RPM} / 60$ ), and  $g$  is the standard acceleration of gravity ( $9807 \text{ mm/s}^2$ ). After substitution:

$$RCF = 1.12 r \left( \frac{\text{RPM}}{1000} \right)^2$$

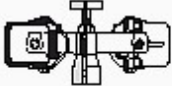
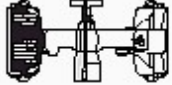

## AVAILABLE ROTORS

The following Beckman Coulter rotors can be used in the Allegra X-15R centrifuge. The rotors are described in individual manuals that accompany each rotor.

Rotor Profile and Description	Rotor Selection Code	Max RPM*	Max RCF† (× g) at $r_{max}$	Number of Tubes × Nominal Capacity	Rotor Manual Number
FX6100 Fixed Angle  $r_{max} = 98.0 \text{ mm}$	FX6100	10 200	11 400	6 × 100 mL	GX-TB-005
SX4750 Swinging Bucket  Tube-and-bottle buckets, $r_{max} = 207.8 \text{ mm}$  Multiwell-plate carriers, $r_{max} = 183.2 \text{ mm}$	SX4750 SX4750 $\mu$	4 750 4 450	5 250 4 050	4 × 750 mL 4 × 96 mL	GX-TB-003
SX4750A Swinging Bucket (ARIES)  $r_{max} = 207.8 \text{ mm}$	SX4750A	4 750	5 250	4 × 750 mL	GX-TB-004

\* Maximum speeds are based on a solution density of 1.2 g/mL. At upper temperature and humidity ambient conditions, swinging bucket rotor speed may require reduction.

† Relative Centrifugal Field (RCF) is the ratio of the centrifugal acceleration at a specified radius and speed ( $r\omega^2$ ) to the standard acceleration of gravity ( $g$ ) according to the following formula:

$$RCF = \frac{r\omega^2}{g}$$

where  $r$  is the radius in millimeters,  $\omega$  is the angular velocity in radians per second ( $2\pi \text{ RPM} / 60$ ), and  $g$  is the standard acceleration of gravity ( $9807 \text{ mm/s}^2$ ). After substitution:

$$RCF = 1.12r \left( \frac{\text{RPM}}{1000} \right)^2$$

## **CENTRIFUGE CHASSIS**

### **HOUSING**

The centrifuge housing is made of sheet steel and structural foam and is finished with acrylic baking enamel paint. The control panel overlay is made of coated polystyrene copolymer. The right and left side front panels are made of high-impact polystyrene structural foam coated with enamel.

### **DOOR**

The aluminum and structural foam door is secured to the housing by solid hinges. A window in the center allows strobe viewing. When the door is closed, the locking system engages. The door is locked when a run is in progress and can be opened only when the rotor is stopped and the LED next to the [Door] key is lit. If there is a power failure, the door lock can be manually tripped for sample recovery (see Section 4, Troubleshooting).

### **ROTOR CHAMBER**

The aluminum rotor chamber is coated with a chemical resistant epoxy finish. The chamber is sealed by a labyrinth of four rubber gaskets.

### **TEMPERATURE SENSING AND CONTROL**

With the power on, the temperature control system is activated when the door is closed and locked. A sensor in the rotor chamber continuously monitors chamber temperature. The microprocessor calculates the required chamber temperature to maintain the selected rotor temperature. Run temperature in the Allegra X-12R, X-15R can be set between  $-10$  and  $+40^{\circ}\text{C}$ . Temperature in the Allegra X-12 is factory set at  $20^{\circ}\text{C}$ , and is maintained at between  $18$  and  $22^{\circ}\text{C}$  to prevent sample heating..

**NOTE** To avoid chamber icing, refrigeration is off when the door is open.  
The centrifuge door must be closed and locked for the refrigeration system to begin operating.

### **DRIVE**

The asynchronous direct-drive motor is brushless for clean, quiet operation. The resilient suspension ensures that loads will not be disturbed by vibration, and prevents damage to the drive shaft if an imbalance occurs during centrifugation. Maximum acceleration and deceleration may be selected to allow fast processing of samples; alternately, delicate gradients may be preserved using slower acceleration and deceleration.

### **SAFETY FEATURES**

Safety features include the following:

### **PROTECTIVE RING**

A structural steel ring surrounding the rotor chamber provides full operator protection.

### **IMBALANCE DETECTOR**

An imbalance detector monitors the rotor during the run, causing automatic shutdown if rotor loads are severely out of balance. At low speeds, an incorrectly loaded rotor can cause an imbalance. Rotor instability can also occur if the instrument is moved, or if it is not resting level on the table (see Section 4, TROUBLESHOOTING).

### **OVERSPEED AND ROTOR IDENTIFICATION SYSTEM**

A rotor identification system prevents the installed rotor from running above its maximum rated speed. During acceleration the microprocessor checks the magnetic rotor identification. If the system identifies a rotor different than the one entered by the user, the system shuts down the run and displays an error message. Speed is limited to the maximum safe speed of the identified rotor.



## 2.1 SAFETY NOTICE

This safety notice summarizes information basic to the safe operation of the equipment described in this manual. The international symbol displayed above is a reminder that all safety instructions should be read and understood before installation, operation, maintenance, or repair of this centrifuge. When you see the symbol on other pages, pay special attention to the safety information presented. Observance of safety precautions will also help to avoid actions that could damage or adversely affect the performance of the centrifuge.

### **Safety During Installation and/or Maintenance**

The centrifuges X-12/R weighs 121 kg ( 267 lb), X-15R weighs 128 kg (283). Do not attempt to lift or move it without assistance.

Any servicing of this equipment that requires removal of any covers can expose parts that involve the risk of electric shock or personal injury. Make sure that the power switch is off and the centrifuge is disconnected from the main power source, and refer such servicing to qualified personnel.

Do not replace any centrifuge components with parts not specified for use on this instrument.

### **Electrical Safety**

To reduce the risk of electrical shock, this equipment uses a three-wire electrical cord and plug to connect the centrifuge to earth-ground. To preserve this safety feature:

- Make sure that the matching wall outlet receptacle is properly wired and earth-grounded. Check that the line voltage agrees with the voltage listed on the name-rating plate affixed to the centrifuge.
- Never use a three-to-two wire plug adapter.
- Never use a two-wire extension cord or a two-wire non-grounding type of multiple-outlet receptacle strip.

Do not place containers holding liquid on or near the chamber door. If they spill, liquid may get into the centrifuge and damage electrical or mechanical components.

### **Safety Against Risk of Fire**

This centrifuge is not designed for use with materials capable of developing flammable or explosive vapors. Do not centrifuge such materials (such as chloroform or ethyl alcohol)

in this centrifuge nor handle or store them within the 30-cm (1-ft) area surrounding the centrifuge.

### **Mechanical Safety**

For safe operation of the equipment, observe the following:

- Use only the rotors and accessories designed for use in this centrifuge.
- Do not exceed the maximum rated speed of the rotor in use.
- NEVER attempt to slow or stop the rotor by hand.
- Do not lift or move the centrifuge while the rotor is spinning.
- NEVER attempt to override the door interlock system while the rotor is spinning.
- Maintain a 7.6-cm (3-in.) clearance envelope around the centrifuge while it is running. During operation you should come within the envelope only to adjust instrument controls, if necessary.  
Never bring any flammable substances within the 30-cm (1-ft) area surrounding the centrifuge.  
Never lean on the centrifuge or place items on the centrifuge while it is operating.

### **Chemical and Biological Safety**

Normal operation may involve the use of solutions and test samples that are pathogenic, toxic, or radioactive. Such materials should not be used in this centrifuge, however, unless *all necessary safety precautions are taken*.

- Observe all cautionary information printed on the original solution containers prior to their use.
- Handle body fluids with care because they can transmit disease. No known test offers complete assurance that they are free of micro-organisms. Some of the most virulent—Hepatitis (B and C) and HIV (I–V) viruses, atypical mycobacteria, and certain systemic fungi—further emphasize the need for aerosol protection. Handle other infectious samples according to good laboratory procedures and methods to prevent spread of disease. Because spills may generate aerosols, observe proper safety precautions for aerosol containment. Do not run toxic, pathogenic, or radioactive materials in this centrifuge without taking appropriate safety precautions. Biosafe containment should be used when Risk Group II materials (as identified in the World Health Organization *Laboratory Biosafety Manual*) are handled; materials of a higher group require more than one level of protection.
- Dispose of all waste solutions according to appropriate environmental health and safety

guidelines.

**It is your responsibility to decontaminate the centrifuge and accessories before requesting service by Beckman Coulter.**

## **2.2 Allegra X-12/R, X-15R Installation Requirements**

The Allegra X-12/R, X-15R model centrifuge is customer installed. Installation requirements for power and location are described below.

### ***Warning***

**Do not place the centrifuge near areas containing flammable reagents or combustible fluids. Vapors from these materials could enter the centrifuge air system and be ignited by the motor.**

### **SPACE REQUIREMENTS**

- Select a location away from heat-producing laboratory equipment, with sufficient ventilation to allow for heat dissipation.
- Position the centrifuge on a level surface such as a sturdy table or laboratory bench that can support the weight of the centrifuge X-12/R (121 kg/ 267 lb) or X-15R 128 (283) and resist vibration.
- Relative humidity should not exceed 75% (noncondensing)
- In addition to space for the centrifuge itself, allow 7.6 cm (3 in) clearances at the sides and back of the centrifuge to ensure sufficient air circulation. ( See Figure 1)

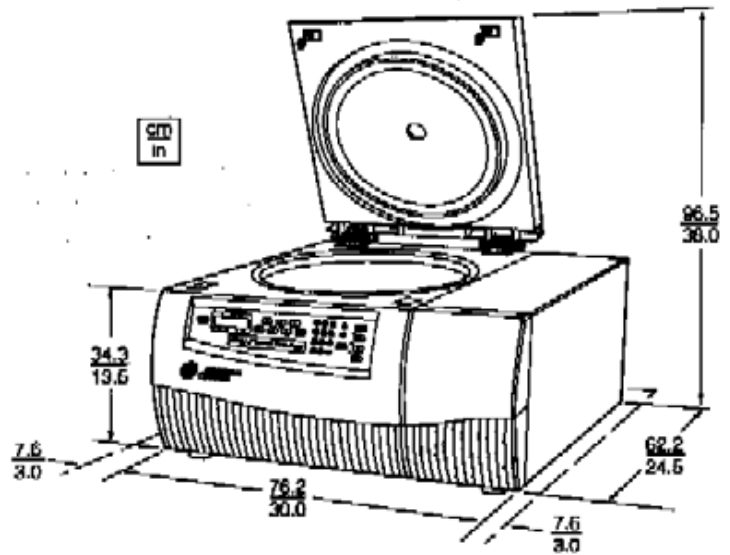

**Figure 1. Centrifuge Dimensions**

To reduce the risk of electrical shock, this centrifuge uses 2.5m (8 ft) three-wire electrical cord (attached to the power connector at the rear of the instrument) and plug for use in North America is the NEMA 6-15P; a NEMA 6-15R socket should be available. (Contact your local Beckman Coulter office for specific information regarding local requirements). To preserve this safety feature:

- Make sure that the matching wall outlet receptacle is properly wired and earth-grounded. Check that the line voltage agrees with the voltage listed on the name rating plate affixed to the centrifuge.
- Never use a three-to-two wire plug adapter
- Never use a three-to-two-wire extension cord or a two-wire non-grounding type of multiple-outlet receptacle strip.
- If there is any question about voltage, have a qualified service person measure it under load while the drive is operating.

To ensure safety the centrifuge should be wired to a remote emergency switch (preferably outside the room where the centrifuge is housed, or adjacent to the exit from that room), in order to disconnect the instrument from the main power source in case of a malfunction.

## **Rotor Attachment**

It is extremely important for a safe centrifuge operation that the rotor attachment to the drive shaft is free of play. Otherwise shifts between drive and rotor can develop. Consequences of this are bent shafts as well as damage to rotors, rotor chamber, etc.

Allegra X-12/R, X-15R centrifuges avoid this by using a conical seat and an additional expanding connection at the drive shaft. The conical seat is located above the bearing plate, and the cross-slit end of the shaft with inner cone is the expanding connection. The counterpart is the boring of the rotor, which is conical at the bottom end.

The rotor is placed onto the drive shaft and the handle is being used to tighten the rotor onto the shaft. When tightening the spring washers packet is compressed as far as physically possible. The resulting tension load forces the rotor onto the cone and thus ensures that the bottom end of the rotor boring is free of play. When tightening the handle further, the cone at the screw spreads the upper end of the cross-slit shaft apart and thus also presses it against the upper end of the rotor boring.

Be sure to inform the user of the importance of a secure seating of the rotor and the principle of the attachment.

**Caution:** Warn the user against possible handling errors and their consequences!

## Centrifuge Anchoring Kit for Allegra X-12/R, X-15R

### SECURING THE CENTRIFUGE TO THE BENCH

Allegra X-12/R, X-15R centrifuges are certified to meet the requirements of the European CE mark. To meet these requirements, the centrifuge must be secured to the bench using the anchoring hardware shipped with the instrument. This will prevent the centrifuge from moving in the unlikely event of a rotor mishap. Complete instructions for installing the anchoring kit are packaged with hardware, which is shipped with the centrifuge. The instructions (publication GX-TB-002A) include a full-size template to be used as a guide for drilling holes in the bench. Refer to this document for additional installation instructions.

### 2.3 Customer Training and Instrument Demo

The following check list is useful when customer training is required.

Refer to User's Manual for all of the following:

#### **Explain:**

Rotors	This instrument allows use of three different rotors: SX 4750 Swinging bucket Aries and non Aries/ Round bucket and microtiter plates (non Aries only) FX 6100 Fixed angle rotor with 6x 100 ml.
Warranty	Rotor warranty is 1 year.
Maintenance	Cleaning and lubricating as required.
Responsibility	Customer is responsible to maintain and prevent rotor from corrosion and damage.
Cautions	Always use all four buckets or 2 buckets and 2 carriers and balance the loads accordingly.

#### Descriptions of instrument

Functions	Explain overall functions.
Controls	Describe control function of each individual key, program mode.
Indicators	Show the different displays and explain audible alerts.
Rotor chamber	Instruct to clean and dry chamber after spill and between runs.



Temperatures sensing and control

Explain that the system is measuring chamber temperature not sample temperature.

Drive

Explain drive is Induction drive and does not require maintenance.

Safety features

Explain door lock and rotor Id, barrier and imbalance features, Name rating plate, serial number

## Test Run

**NOTE: The instrument must be plugged in and the power switch turned to on position (1) before the door can be opened.**

We recommend that you make a test run to ensure that the instrument is in proper operating condition following shipment.

### Run the instrument

1. Open the chamber door.
2. Enter speed of 3,000 RPM
3. Enter Temp 20C
4. Enter Time 30 min.
5. Perform a test run to verify parameter input.
6. Verify the temperature and speed control are functioning.
7. If the test run is satisfactory then proceed to instruct the customer on proper operation of the instrument.

Show the customer how to setup a simple run. Observe the customer as they setup the run.

Explain:

Troubleshooting

Customer maintenance items

Beckman Coulter Field Service, service agreements, etc.

Accessories and options that are available for the instrument

How to get applications support from Beckman Coulter Inc.

## 3.1 Mechanical Systems

---

**Warning:** Unplug the centrifuge or turn off and lock out the main wall circuit breaker before removing an instrument panel.

**Warning:** As long as the yellow LED on the Motor driver board is lit, the Bus Voltage is still present. Wait until LED is off.

### 3.1.1 Front Panel Replacement

- A. Open lid, TURN POWER SWITCH OFF AND DISCONNECT POWER CORD.
- B. Remove the four screws on top housing and open the front panel.
- C. Disconnect all harness connections.
- D. Remove Control board, driver board and VFD display by removing attached hardware.
- E. Remove the four screws that attach the hinges to the front panel.
- E. Remove the screws that hold the cable in place.
- F. Remove front panel.
- G. Reverse the above steps to replace the control panel.

**Warning:** Unplug the centrifuge or turn off and lock out the main wall circuit breaker before removing an instrument panel.

**Warning:** As long as the yellow LED on the Motor driver board is lit, the Bus Voltage is still present. Wait until LED is off.

### 3.1.2 Drive Motor Replacement Allegra X-12 series

\*\*Materials needed: Silicone RTV 108 (342778)

- A. Open lid, TURN POWER SWITCH OFF AND DISCONNECT POWER CORD.
- B. Remove four screws on the top housing to open the front panel.
- C. Disconnect the drive connector J16 from the Motor Driver board and remove from the cable holder.
- D. Disconnect the ground connector from the motor housing.
- E. Disconnect the tach sensor connector J10, Rotor ID connector J8 and Motor Overtemp connector J11 from the Control Board and remove the cables from the cable holder.
- F. Remove the boot from the bowl.
- G. Remove two screws on top of the drive that hold the imbalance flag bracket in place.
- H. Remove four motor mounting lock-nuts by holding the Philips screws underneath the suspension plate with a 90° angle Philips screwdriver in place.
- I. Remove washers, grommets and screws

- J. Pull drive upward, including the white support ring, while feeding the motor harness through the opening. To ease the removal of the brass cone use a screwdriver to widen the slit and pull the cone of the shaft.
- K. Remove three Phillips screws that attach the Rotor ID sensor plate and retain three spacers, remove the rotor ID sensor.
- L. To reinstall drive, feed harness through the drive opening.
- M. Make sure the white ring lines up with the mounting holes in the suspension plate.
- N. Carefully set drive down on the suspension plate and ensure the harness is not pinched.
- O. Lightly coat the four new grommets with vacuum grease.
- P. Place grommets, washers and nuts on top of drive, make sure screws stay in place and being held with angled Philips screwdriver while tightening the nuts.
- Q. Tighten the four lock-nuts until the specified dimension between the suspension plate and top of the white ring equals 5/8 inch.
- Q. Reinstall Rotor ID and cone.
- R. Reconnect all connectors and lock in the cable in the cable holders.
- S. Reinstall imbalance bracket.
  - \*\* Remove silicone sealant from chamber lip and clean boot outer groove of cured silicone. Apply small bead of GE Silicone #108 to the outer groove of the boot.
- T. Reinstall boot.
- U. Reinstall front panel.

**NOTE:** The boot must remain completely seated down around the motor cover to prevent contact with the rotor.

**Warning:** **Unplug the centrifuge or turn off and lock out the main wall circuit breaker before removing an instrument panel.**

Warning: As long as the yellow LED on the Motor driver board is lit, the Bus Voltage is still present. Wait until LED is off.

### 3.1.3 Drive Motor Replacement Allegra X-15R

\*\*Materials needed: Silicone RTV 108 (342778)

- A. Open lid, TURN POWER SWITCH OFF AND DISCONNECT POWER CORD.
- B. Remove four screws on the top housing to open the front panel.
- C. Disconnect the drive connector J16 from the Motor Driver board and remove the cable from the cable holder.
- D. Disconnect the tach sensor connector J10, Rotor ID connector J8 and motor overtemp connector J11 from the Control Board.
- E. Disconnect the ground wire and remove the cables from the cable holder.
- F. Remove the boot from the bowl.
- G. Remove four motor mounting nuts.
- H. Pull drive upward while feeding the motor harness through the opening.

- I. To ease the removal of the brass cone use a screwdriver to widen the slit and pull the cone of the shaft.
- J. Remove three Phillips screws that attach the Rotor ID sensor plate and retain three spacers, remove rotor ID sensor.
- K. To reinstall drive, feed harness through the drive opening.
- L. Carefully set the drive down on the suspension plate and ensure that the harness is not pinched.
- M. Insure that the four silicon sleeves are in place.
- J. Tighten the four nuts
- K. Reinstall Rotor ID sensor and cone.
- L. Reconnect all connectors and lock the cable in the cable holders.
  - \*\* Remove silicone sealant from chamber lip. Apply small bead of GE Silicone #108 to the outer groove of a new boot. Reinstall boot.
- M. Reinstall front panel.

**NOTE:** The boot must remain completely seated down around the motor cover to prevent contact with the rotor.

**Warning:** **Unplug the centrifuge or turn off and lock out the main wall circuit breaker before removing an instrument panel.**

Warning: As long as the yellow LED on the Motor driver board is lit, the Bus Voltage is still present. Wait until LED is off.

### 3.1.4 Housing Removal

**NOTE:** A second person might be needed to support the lifting of the housing

- A. Remove front panel per step 3.1.1.
- B. Remove the refrigeration front cover by removing two screws on top and two screws on the bottom.
- C. If the instrument is anchored, remove the four screws attaching the anchor brackets to the frame.
- D. Remove four hex screws that fasten the housing to the chassis on each side and also remove two screws in the front where the housing is attached to the base plate.
- E. Remove five screws in the back and another six screws that hold the electrical panel in place.
- F. Disconnect the harness attached to the circuit breaker
- G. Pull the emergency release cable out of the base plate.
- H. Make sure the door is closed when you lift the housing of the instrument.
- I. Disconnect harness attached to the left and right hand latch assembly.
- J. Reverse the above steps to reinstall the housing and electrical panel.

**Warning:** Unplug the centrifuge or turn off and lock out the main wall circuit breaker before removing an instrument panel.

**Warning:** As long as the yellow LED on the Motor driver board is lit, the Bus Voltage is still present. Wait until LED is off.

### 3.1.4 Door Latch 392330, 392329 Replacement X-12/R

\*\*Materials needed: Cord, Dacron (978139), Adhesive, Loctite 416 (6000808).

- A. Open front panel as described in 3.1.1.
- B. Remove harness from latch assembly.
- C. Remove the emergency release string from the latch by cutting the cord knot located in the plug in the base of the instrument.
- D. Remove three nuts that hold the latch assembly in place.
- E. Remove latch
- F. Tie cord onto latch pivot bracket and secure it with Loctite.
- G. Replace latch, refer to BCI drawing number 392300 for adjustment of the latch.
- H. Tie both latch cords together so that both cords are the same length.
- I. Reinstall the latch cords in the plug in the base of the instrument.
- J. Make sure that the emergency release is functioning.

**Warning:** Unplug the centrifuge or turn off and lock out the main wall circuit breaker before removing an instrument panel.

**Warning:** As long as the yellow LED on the Motor driver board is lit, the Bus Voltage is still present. Wait until LED is off.

### 3.1.5 Door Latch 392900 Replacement X-15R

\*\*Materials needed: Tether (392998), Door release, Adhesive, Loctite 416 (6000808).

- K. Open front panel as described in 3.1.1.
- L. Remove harness from latch assembly.
- M. Remove the emergency release string from the latch by cutting the cord knot located in the plug in the base of the instrument.
- N. Remove two nuts that hold the latch assembly in place.
- O. Remove latch
- P. Tie cord onto latch pivot bracket and secure it with Loctite.
- Q. When installing the new latch it needs to be moved all the way to the left before closing the door and adjusting the gap of .09 between latch and striker (BCI drawing number 392930).
- R. Tie both latch cords together so that both cords are the same length.
- S. Reinstall the latch cords in the plug in the base of the instrument.
- T. Make sure that the emergency release is functioning.

### 3.1.6 Hinge or Door Replacement

- A. Open door completely.
- C. Remove electrical panel.
- D. Remove the three hex screws attaching the hinges to the back of the instrument housing.
- E. While supporting the door, remove (4) nuts attached inside the housing
- F. Remove door from housing and place on a flat surface.
- H. Replace hinges on the left or right side while door is off unit.
- I. Reinstall the door by installing all screws in place.
- I. Adjust striker (door locking eye bolt) to maintain a good seal between the door and the bowl gaskets. The top of the striker to top of door skin distance is “1.500 +/- .050” Refer to BCI drawing 392300.
- J. Tighten the locking nut to prevent rotation of the striker.

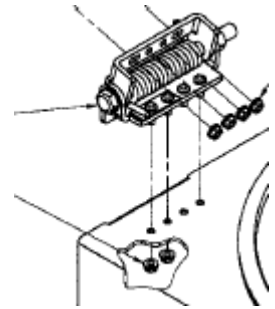

**NOTE:** Door hinges are nonadjustable.

*If door won't stay at angle when open install spacer 393045 by removing two nuts on each hinge and slide shim into place. Tie nuts accordingly, see attached picture.*

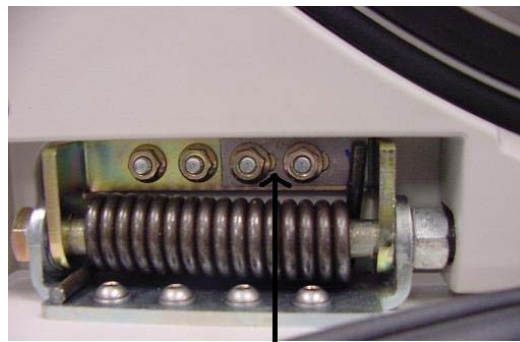

P/N 393045 TO BE ADDED AS NECESSARY

**Warning:** Unplug the centrifuge or turn off and lock out the main wall circuit breaker before removing an instrument panel.

**Warning:** As long as the yellow LED on the Motor driver board is lit, the Bus Voltage is still present. Wait until LED is off.

### 3.1.7 Brake Resistor, EMI Filter or Receptacle Replacement

- A. Remove the electrical panel by removing 8 button head screws attached in the back of the instrument.
- B. Remove two screws that hold the brake resistor bracket in place.
- C. Replace brake resistor
- D. Remove two screws that are attached to the EMI filter and replace filter.
- E. Remove two screws that are attached to the receptacle and replace receptacle.

### 3.1.8 Imbalance Adjustment and Calibration Allegra X-12 series

Imbalance Calibration: The centrifuge is calibrated for imbalance prior to shipment. The calibration value can be reentered by pressing “ENTER”, “613” for each individual rotor. Recalibration is required if the optical flag is replaced, moved or if a new control board or motor is installed. To run a rotor a calibration value is needed. The rotors used for calibration depend on the library of rotors present in the customer’s lab.

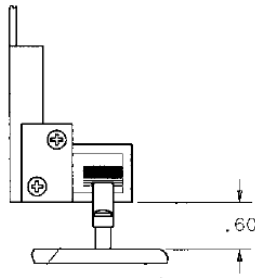

Flag needs to be adjusted at .6 inch.

- A. Refer to the table below to determine which rotor and loads to be used for calibration.
- B. From the centrifuge rotor table, select the appropriate rotor.
- C. Install the appropriate test loads per the table below.
- D. Press “ENTER”, “611” “ENTER”, “START”.
- E. The centrifuge will run the rotor to speed and brake to a stop.
- F. Press “CE” when prompted by the centrifuge.
- G. Repeat steps A through F as required.

Calibration Rotors		Customer Rotor Library		Loads to be used
<b>SX4750</b>		<b>SX4750</b>		<b>2x 700g pos 1&amp;2+2x 750g (1.2d) Pos 3&amp;4</b>
<b>SX4750A</b>			<b>SX4750A</b>	<b>2x 750g pos 1&amp;2 +2x 625g (1.2d) Pos 3&amp;4</b>
<b>FX6100</b>			<b>FX6100</b>	<b>5x 47ml + 1x 62ml (water)</b>

**Warning:** Unplug the centrifuge or turn off and lock out the main wall circuit breaker before removing an instrument panel.

**Warning:** As long as the yellow LED on the Motor driver board is lit, the Bus Voltage is still present. Wait until LED is off.

### 3.1.9 Imbalance Calibration Allegra X-15R

**Note:**

To reenter calibration value after clearing S1, S2, S7 diagnostics use ENTER 616. A calibration is necessary when changing the optical flag, optical sensor, motor or motor mounts.

#### Sensor Calibration

- A. Turn Instrument Power off.
- B. Remove four screws and open front panel.
- C. Locate the optical flag and move it out of the light path of the optical sensor, or a second method would be to loosen the two screws that hold the sensor bracket in place and pull the sensor bracket all the way to the front of the instrument.
- D. Make sure the light path of the optical sensor is clear of any object during calibration.
- E. Close front panel.
- F. Turn instrument power back on.
- G. Use sequence ENTER 615 to calibrate the sensor.
- H. The calibration value can be displayed by pressing ENTER 614.

**Note:**

An SX4750 rotor needs to be installed before adjusting the voltage below. Before proceedings with adjustments make sure the flag is free of scratches.

#### Flag Calibration

- A. Open the front panel.
- B. *Ensure the optical flag is in position within the optical sensor.*
- C. Connect a DVM between TP 19 and TP 30.
- D. Loosen two screws and move the sensor bracket all the way toward the drive to read < 1.5 VDC.
- E. Pull the bracket very slowly towards the front of the instrument until a reading of 2.5 +/- 0.1 Volts DC is established. The sensor should be positioned in the middle of the flag. If the bracket is pulled to far a second 2.5 V is measurable and the sensor is positioned at the edge of the flag which is incorrect and will cause I6 diagnostics.
- F. Push the rotor to the 12'o clock position and release it.
- G. After the rotor moved back to its center position check for 2.5 Volts DC again and adjust bracket if necessary.
- H.. Pull the rotor to the 6 o'clock position and release it.
- I. After the rotor moved back to its center position check for 2.5 Volts DC again and adjust bracket if necessary.



- J. If voltage is within 2.5 +/- .1Volts DC after moving the rotor in both directions tie down the bracket.
- K. Perform a test run with a balanced rotor load and empty rotor. Monitor the 2.5 V DC
- L. If the Voltage is within 2.5+/- .1V between a loaded or empty rotor the calibration is complete.
- M. If it isn't within the tolerance perform steps E to L again.

Typically, 10-15 g should cause imbalance error I1.

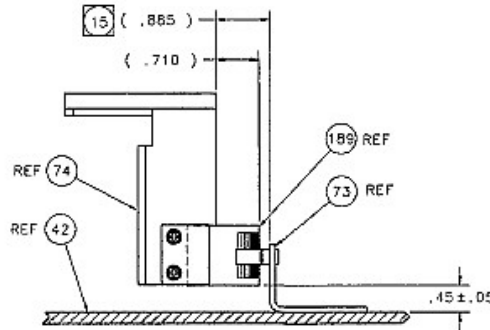

## 3.2 Temperature Control Systems

**Warning:** Unplug the centrifuge or turn off and lock out the main wall circuit breaker before removing an instrument panel.

**Warning:** As long as the yellow LED on the Motor driver board is lit, the Bus Voltage is still present. Wait until LED is off.

### 3.2.1 Refrigeration System Safety

**Warning:** Refer to the safety notices in the front of this manual for cautionary notes when working with refrigeration system. Read all brazing safety notes. Always recover the refrigerant.

### 3.2.2 Refrigeration Functional Test

- A. The SX4750 swinging bucket rotor is recommended for this test. Replace loaded buckets with empty buckets. Temperature measurements are performed by using 40ml of glycerol in two of the opposing buckets.
- B. To precool the rotor and chamber, set temperature to -2° C, speed to 2000 RPM and time for 30 minutes.

- C. After precool, set the temperature to  $-10^{\circ}\text{C}$  and increase speed to 3750 RPM. Set the time for 15 minutes.
- D. At the instant the time shuts off, record the indicated temperature. The reading should be  $-1^{\circ}\text{C}$  or colder for 60 Hz units and  $+1^{\circ}\text{C}$  or colder for 50 Hz units.
- E. When the rotor stops use a temperature meter to measure the actual temperature of the sample (glycerol) and then record the reading.
- F. The difference between D and E should be within  $\pm 2^{\circ}\text{C}$ .

If functional test fails, proceed to 3.2.3

### **3.2.3 Checking the Refrigerant Charge**

- A. Open front panel as described in 3.1.1 and remove four screws and the right front cover.
- B. Connect charging manifold (“Access” control valves, P/N 964411, simplify connection to Shrader service valves) and refrigerant supply as shown in Figure 3-1.
- C. Before opening the Shrader valves, purge the charging manifold and hoses of air with R404a refrigerant supply at the low-side and high-side service valves.
- D. Precool Chamber to  $-10^{\circ}\text{C}$  and install rotor SX 4750. Run the rotor at 3750RPM for ten minutes and then take pressure readings.
- F. Compare the pressures to be as shown in Graph 1A or 1B.
- G. If system pressures are low, add refrigerant R404a as a liquid at the low-side until the required pressure is indicated. Proceed to step 3.2.4 to check for leaks.
- H. After removing refrigeration manifold, and access valves, ensure the service valve caps are replaced and tightened. Insulate the low-side service valve with “Presstite” insulation tape.

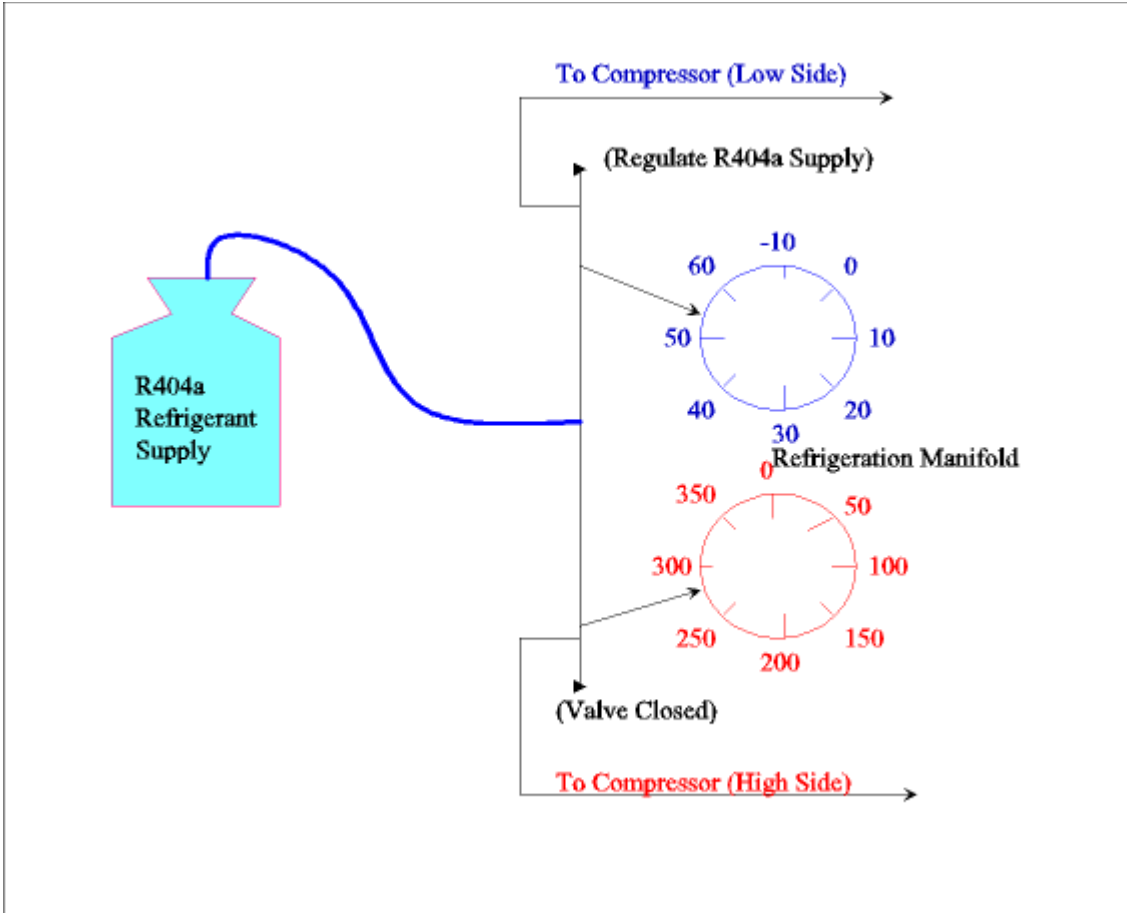
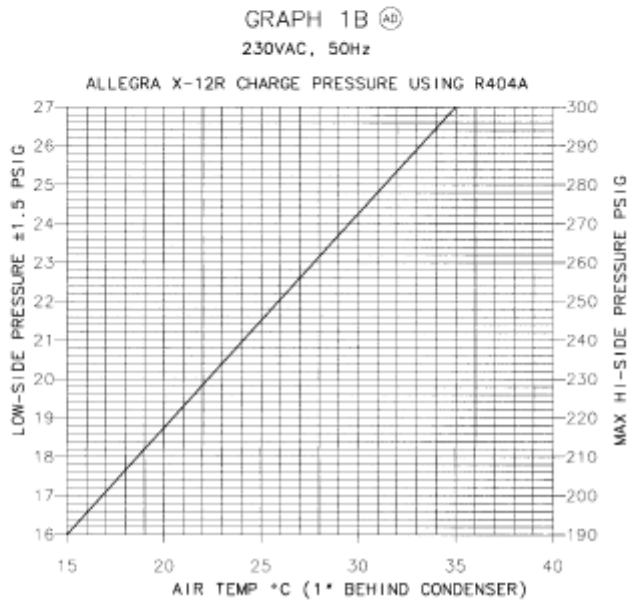
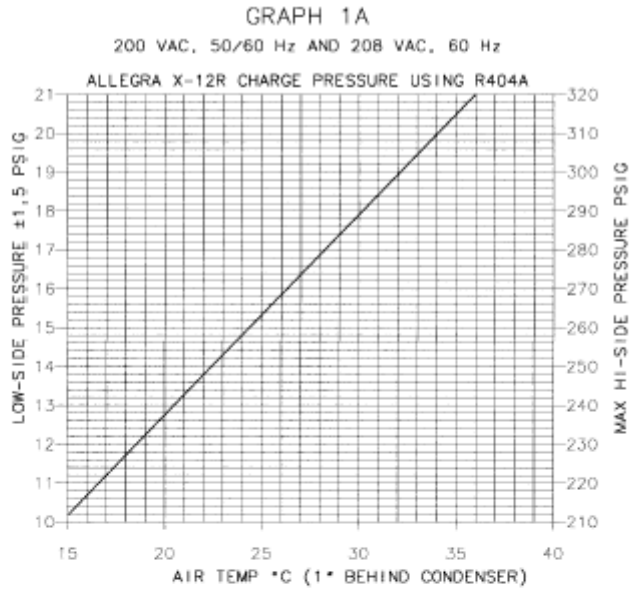

Figure 3-1

Allegra X-12R



**Allegra X-15R**

GRAPH 1A: 208VAC 50/60 Hz

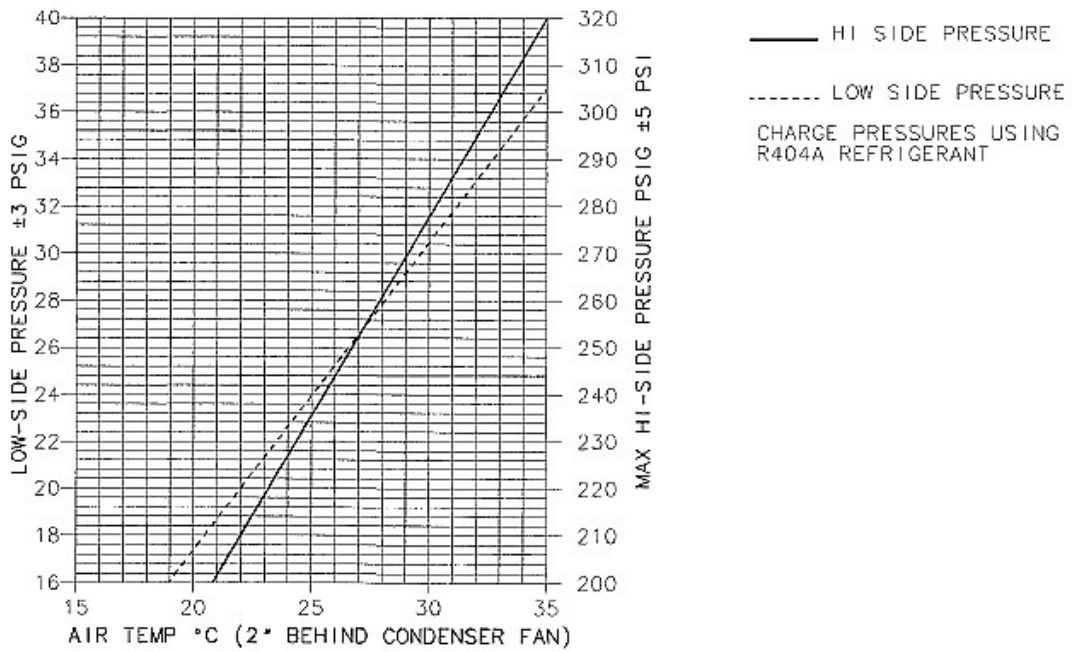

GRAPH 1B: 230VAC 50 Hz

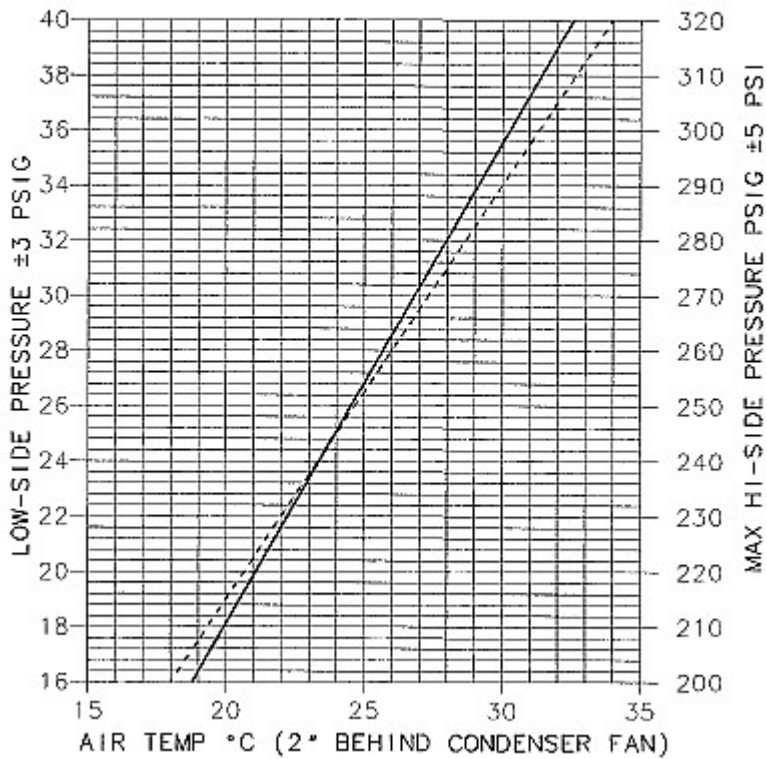
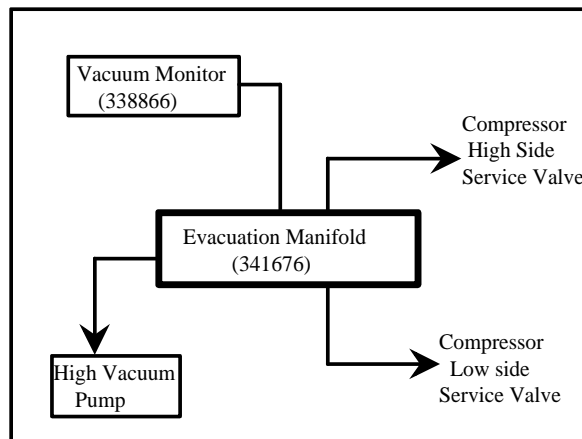

**Figure 3-2****3.2.4 Leak Test and Evacuation****LEAK TEST**

- A. Remove front panel and instrument housing as outlined in the mechanical systems section.
- B. Connect the charging manifold per step 3.2.2.
- C. Purge charging manifold and hoses of air before adding refrigerant to the system.
- D. If system pressures are low, add refrigerant R404a as a liquid to the low-side with compressor running.
- E. Turn main power off. Allow pressures to equilibrate then test for leaks. (Requires a leak detector that will detect R404a).
- F. Correct all leaks found in the system.

**EVACUATION**

- A. Evacuate the system to 50 microns by using an evacuation manifold and a high capacity vacuum pump, as shown in figure 3-3. After a vacuum is obtained turn compressor on for about 2-3 seconds to remove moisture trapped in compressor, turn compressor off and allow system to achieve 50 microns of vacuum.
- B. Close both access service valves at the compressor while the vacuum pump continues to run. Once the valves are closed, turn off the vacuum pump and remove the evacuation manifold.
- B. Connect charging manifold and R404a refrigerant supply per procedure in step 3.2.3.

**FIGURE 3 - 3**

### 3.2.5 Chamber Bowl Replacement (Refrigerated)

- A. Remove control panel, per step 3.1.1.
- B. Remove housing, per step 3.1.3.
- C. Disconnect harnesses in brazing area and position them to avoid heat damage.
- D. Recover refrigerant from system.
- E. Remove Schrader valves prior to brazing.

**CAUTION:** Do not damage or cut the capillary tube located inside the 1/4 inch tubing.

- G. Observe brazing precautions. Unbrazed both refrigeration chamber lines .
- H. Remove chamber support mounting hardware from bottom side of chassis.
- I. Remove the barrier if necessary by removing two screws attached to each barrier bracket.
- J. Remove chamber.
- K. Re-assemble the chamber, by performing the above steps in reverse order.  
**DO NOT CUT OR DAMAGE THE CAPILLARY TUBE.** Evacuate, charge and leak test the refrigeration system per step 3.2.3.

**NOTE:** Ensure chamber gasket and door form a good seal prior to performing refrigeration tests.

### 3.2.6 Temperature Sensor Check

1. Turn power off and open the front panel.
2. Remove P7 on the control board for the Thermistor.
3. Connect your VOM across P7 pins 1&2.
4. The value displayed on the meter should match the value given in the chart below.

## Resistance versus Temperature

**10 K at 25 C**

Temp. C	Res.	Temp. C	Res.	Temp. C	Res.	Temp. C	Res.
-50	441.3K	0	29.49K	20	12.26K	40	5592
-40	239.8K	1	28.15K	21	11.77K	41	5389
-30	135.2K	2	26.89K	22	11.29K	42	5193
-20	78.91K	3	25.69K	23	10.84K	43	5006
-10	47.54K	4	24.55K	24	10.41K	44	4827
-1	30.89K	5	23.46K	25	10.00K	45	4655
		6	22.43K	26	9605	46	4480
		7	21.45K	27	9227	47	4331
		8	20.52K	28	8867	48	4179
		9	19.63K	29	8523	49	4033
		10	18.79K	30	8194	50	3893
		11	17.89K	31	7880	51	3758
		12	17.22K	32	7579	52	3629
60	2760	13	16.49K	33	7291	53	3504
70	1990	14	15.79K	34	7016	54	3385
80	1458	15	15.13K	35	6752	55	3270
90	1084	16	14.50K	36	6500	56	3160
100	816.8	17	13.90K	37	6258	57	3054
110	623.5	18	13.33K	38	6026	58	2952
120	481.8	19	12.79K	39	5805	59	2854

### 3.3 Troubleshooting

---



### 3.3.1 Component Resistance Checks

208V Compressor	
Common to Run	5.7 ohm
Common to Start	2.5 ohm
Drive	4.2 ohm

### 3.3.2 Diagnostic Messages

There are 9 key categories of diagnostics in the Allegra X-12 series centrifuge.

- System (S. EPROM, RAM, Software problem)
- Power (P. Power failure)
- Door (L. Door open, Unlatched, Interlock malfunction)
- Imbalance (I. Imbalanced rotor)
- Rotor (R. Dynamic rotor ID)
- Drive (D. Driver board failure, Board overtemp, Over bus voltage, Communication problem)
- Speed (H. Overspeed, Speed not controlling, No Tach present)
- Temp (T. Overtemp)
- Refrigeration (C. Temperature control)

### System Diagnostics

All System diagnostics are only checked during power up, When a System diagnostic occurs, the user must call the filed service and cannot clear the diagnostic by pressing the [CE] key.

Diag. #	Description	Action taken	When issued	Display
S1	Program in FLASH ROM changed	Shutdown, no brake	On power up/ reset	S-1 System error, call Service
S5	Software Exception	Shutdown, no brake	Any time	S-5 System error, call Service
S7	Battery backed Ram data changed	Shutdown, no brake	On power up/ reset	S-7 System error, call Service

### Power Diagnostics

Momentary power outage will not terminate the run. A Power diagnostic will be given for a power failure at power glitch or outage. When a Power diagnostic occurs, all program parameters will be saved and the Power diagnostic will be displayed on the VFD.

Diag. #	Description	Action taken	When issued	Display
P1	Hardware power failure indication	Shutdown with brake	On power up/ reset after any power glitch or outage	P-1 Power failure occurred, see manual

### Door Diagnostics

Diag #	Description	Action taken	When issued	Display
L1	Both door strikers not in place	Shutdown, no brake	When running or stopping only	L-1 Door Latch, call Service
L2	Left striker is not in place	Shutdown, no brake	When running, stopping or pressing ENTER START	L-2 Door Latch, call service
L3	Right striker is not in place	Shutdown, no brake	When running, stopping or pressing ENTER START	L-3 Door Latch, call Service
L4	Both door latches are open	Shutdown, no brake	When running, stopping or pressing ENTER START	L-4 Door Latch, call Service
L5	Left door latch open	Shutdown, no brake	When running, stopping or pressing ENTER START	L-5 Door Latch, call Service
L6	Right door latch open	Shutdown, no brake	When running, stopping or pressing ENTER START	L-6 Door Latch, call Service
L7	Cannot open the door	No action	When running, stopping or pressing ENTER START	L-7 Can't Open Door, see manual

### Imbalance Diagnostics

The Allegra X-12/R, X-15R centrifuge has a rotor imbalance detector as used in the Allegra 25/64R. In a situation where an imbalanced rotor is being used an Imbalance diagnostic will be generated and the instrument will brake the run to a stop. The system reports imbalance diagnostic if the sensor reading is positive and the door is closed.

Diag. #	Description	Action taken	When issued	Display
I1	Imbalanced rotor.	Shutdown with brake		I-1 Imbalance, see manual
I2	Bad imbalance detector	Shutdown with brake	Issued when imbalance A/D does not change (Connector not attached)	I-2 Imbalance Error, call Service
I3	Imbalance not calibrated	Shutdown with brake	Issued when Imbalance calibration value for rotor is set to 0. This is the default value when not calibrated.	I-3 Imbalance Error, Call Service
I4	Imbalance sensor not calibrated	Run will not start	Issued when enter/start pressed	I4 -Imbalance Error, call Service
I5	Imbalance flag failure	Run will not start	Issued when enter/start pressed	I5 -Imbalance Error, call Service
I6	Imbalance flag calibration error	Run will not start	Issued when enter/start pressed	I6 -Imbalance Error, call Service

### Temp Diagnostics

### Section 3: Service Procedures

When the software detects the chamber temperature (thermistor) exceeds 50°C, or the software reads the can over temp sensor it will generate an Over temp diagnostic and shutdown the instrument by coasting. There is no minimum chamber temperature requirement or diagnostic.

Diag #	Description	Action taken	When issued	Display
T1	Max temperature exceeded	Shutdown no brake, door locked for 45 min	When thermistor reading exceeds 50C	T-1 Temp, door locks for 45 minutes, call Service
T2	Chamber overtemp	Shutdown no brake, lock door 45 minutes	HW sends signal to control board	T-2 Temp, door locks for 45 minutes, call Service
T3	Motor over temp	Shutdown, no brake	HW sends signal to control board	T-3 Temp, door locks for 45 minutes, see manual

### Refrigeration Diagnostics

When the software detects the set temperature is not controlled within a temperature range an error will be displayed

Diag #	Description	Action taken	When issued	Display
C1	Temp exceeds 5C above set	No action	If reached temp and 4C over set	C-1 Rotor temp exceeds 4C above set
C2	Temp exceeds 8C above set	Shutdown no brake,	If reached temp and 8C above set	C-2 Rotor temp exceeds 8C above set, call Service
C3	Temperature not controlled	Shutdown with brake	Not trending towards set temp	C-3 Temp Error, call Service
C5	Temperature bad reading	Shutdown with brake	Software read an ambiguous temperature reading	C-5 Temp Error, call Service

### Drive Diagnostics

Diag #	Description	Action taken	When issued	Display
D1	Fault not cleared	Shutdown no brake	Driver board issues fault; SW cannot clear	D-1 Drive error, call Service
D2	Fault limit exceeded	Shutdown no brake	More than 2 driver faults occurred during run	D2-Drive Error, call Service
D4	Bus voltage limit exceeded	Shutdown, no brake	SW detects bus voltage over maximum allowed voltage 435 Volt	D-4 Drive error, call Service
D5	Driver not powered	Shutdown, no brake	Drive power lost during run	D-5 Drive Error, call Service
D6	Driver over temperature	Shutdown, no brake	Signal from driver board indicates an over temp	D-6 Drive Error, call Service
D7	Driver not enabled	Shutdown, no brake	Driver not enabled after turning On	D-7 Drive Error, call Service
D8	Driver not established	Shutdown, no brake	Driver not established after turning Off	D-8 Drive Error, call Service
D9	Driver not connected	Shutdown, no brake	Driver board not connected	D-9 Drive Error, call Service

### Speed Diagnostics

Diag. #	Description	Action taken	When issued	Display
H1	Speed not controlled	Shutdown with brake	Speed varies up and down	H-1 Speed error, call Service
H2	Speed exceeded	Shutdown, with brake	Set speed exceeded by 200	H-2 Speed error, call Service
H3	Lost Tach	Shutdown, no brake Door locked for 45 min	Any time during run	H-3 Speed Error, call Service
H4	Set speed not reached	Shutdown with brake	The user set speed took more than reasonable time to reach set speed	H-4 Speed Error, call Service
H5	Lost Tach	Shutdown, no brake Door locked for 45 min	Bad value from TPU reading	H-5 Speed error, call Service
H6	Overspeed rotor magnet verification	Shutdown, no brake Door locked for 45 min	Issued when speed read From rotor magnets is 100 RPM more than maximum Speed for the rotor.	H-6 Speed Error, door locks for 45 min., Call Service

### Rotor Diagnostics

Diag. #	Description	Action taken	When Issued	Display
R1	No index pulse found	Shutdown, with brake	When running, stopping, or pressing ENTER START	R-1 Rotor ID problem, call Service
R2	No code pulse found	Shutdown, with brake	When running, stopping, or pressing ENTER START	R-2 Rotor ID problem, call Service
R3	Setup rotor does not match the chamber rotor	Shutdown, with brake	When running, stopping, or pressing ENTER START	R-3 Rotor ID mismatch, check rotor
R4	No Rotor ID X-12/R only	Shutdown with brake	When system does not detect any Magnets	R-4 No Rotor Match, see Manual
R5	Unknown Rotor in chamber	Shutdown with brake	Magnets detected, but pattern is not one of Allegra X-12 R rotors	R-5 No Rotor Match, see Manual

### 3.3.4 Emergency Access

If facility power fails you will have to restart the run when the power is restored. In the event of an extended power failure, it may be necessary to trip the door-locking mechanism manually to remove the rotor and retrieve your sample.

1. Press the POWER switch to OFF and unplug the power cord from the power source. No displays or LED's are lit.
2. Make sure that the rotor is not spinning. No sound or vibration comes from the centrifuge.

**! WARNING**

**Never attempt to override the door interlock system while the rotor is spinning.**

3. Locate the release device cap underneath the bottom center of the centrifuge (not visible from the centrifuge front).
4. Use a flat-blade screwdriver to pry the cap loose.
5. Insert the screwdriver through the two cords and pull to release. The latch releases and the door opens. If the rotor is still spinning, *close the door and wait until it stops before attempting to remove it.*

**! WARNING**

**Never attempt to slow or stop the rotor by hand.**

6. Reinstall the cap in the opening after sample retrieval.

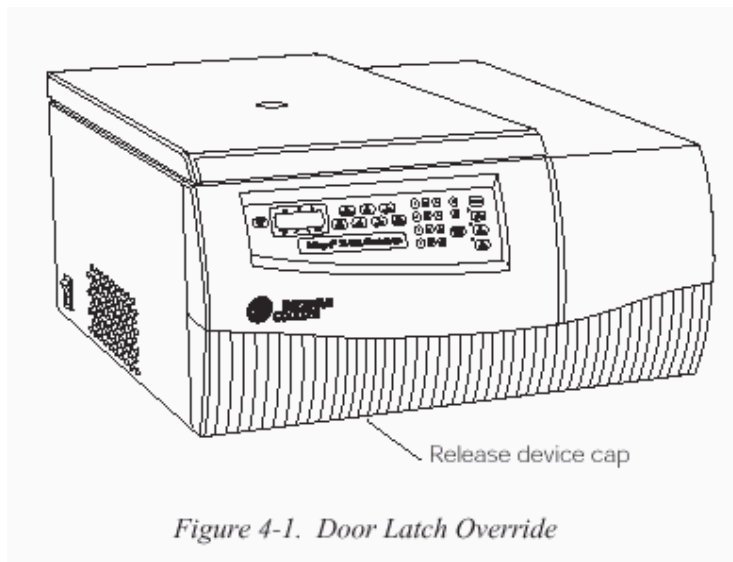

## **3.4 Preventive Maintenance**

---

## Preliminary

Contact the customer prior to making the call. Ask about any current problems, and decontamination of the instrument if necessary. Order any potentially required parts in advance.

### 3.4.1 After Arrival

- Instrument safe to work on (safe positioning and decontamination if necessary).
- Centrifuge identification legible.
- Rotors and accessories safe and usable.
- Update instrument to latest revision. Check latest Service INFO's for updates & kits.
- Run Max. RPM test to check for normal operation.
- Test operation (This is not a certification).

Speed Set	_____	Checked	_____
Temp Set	_____	Checked	_____
Run time Set	_____	Checked	_____

- Safety inspection.

- Wires, Connectors, Boards, Fans
- Vibration mounts
- Labels
- Door, Fuses
- Refrigeration (labels correct etc.)
- Power cord

### 3.4.2 Rotors

### Section 3: Service Procedures

- Lubricate the rotor Tie-down bolt with Spinkote, O-rings with vacuum grease.
- Replace damaged or missing O-rings.
- Check that buckets on swinging bucket rotors swing freely. Clean and apply appropriate lubrication to all friction points.

#### 3.4.3 Drive

- Vibration mounts not sagging or cracked.
- Check fan and blower wiring insulation for cracking/flaking. Replace if needed.
- Clean condenser fan and motor for function.
- Clean condenser fins. In severe cases, high-pressure air may have to be used to free compacted dirt.
- Check latch and door for alignment.
- Tighten door screws.
- Verify line voltage

#### 3.4.4 Electrical and Functional Tests

- Perform all needed updates.
- Final test run (NOTE: This is not a Certification)  
Speed Set \_\_\_\_\_ Checked \_\_\_\_\_  
Temp. Set \_\_\_\_\_ Checked \_\_\_\_\_  
Run time Set \_\_\_\_\_ Checked \_\_\_\_\_
- Check refrigerant level during run only if instrument fails test run when set at lowest temperature of rotor used while controlling at max. speed for the rotor.
- Replace all panels, clean exterior.
  - Notify customer upon completion and inform him/her of any problems found and corrected.

## **4.1 ALLEGRA X-12/R, X-15R CIRCUIT DESCRIPTION**

### **Control Driver Board**

#### **General**

The Control Driver Board (CDB) is a Motorola 68332 based board providing all instrument control.

#### **Power Supply**

A single power supply generates 3 voltages; +24V (LD62), +5V (LD63), and +3.3V (LD65). The +24V supply is not regulated, however the +5V U34 and +3.3V U35 supplies are regulated. The output of the +5V supply feeds the +3.3V regulator. A 2A fuse is in series with the primary winding of the transformer for protection.

VREF is the analog +5 VDC reference. VREF is generated from +24VDC via ZR1, LM4040 a precision voltage reference. This voltage is used for the A/D Converter U25, the Imbalance Circuit, and the Motor Driver Board.

The Power Fail circuit sends a fault signal to the microprocessor if the supply falls below 20V DC.

#### **Driver Board Control**

Via J21

The microprocessor generates PWM signals that are fed to the Driver Board. Other control and status signals such as Drive Enable, Brake and, Fault detection are interfaced to the Driver Board through this connector.

#### **A/D Circuit**

The Analog to Digital Conversion is achieved by using a MCP 3208, 12 bit 8 channel SPI Serial Interface, A/D Converter U25. The A/D converter is referenced to VREF and converts the following signals: DC-Link, Current, Thermistor and Imbalance.

#### **Thermistor**

Via J7

Thermistor is buffered through Op Amp U36A to the A/D Converter U25.

#### **Tach Input**

Via J10

The Tach signal is fed into the microprocessor via TPU6.

#### **Door Interlock Circuit**

The Door Interlock is controlled by LM2917 U106, a Frequency to Voltage Converter, using the TACH Signal as its input.



## Motor Temperature

Via J11

Motor Temp signal is routed to logic and the data bus through J11.

## Sensors

Via J12

Door Latch, Striker Status, and CAN TMP signals are routed to logic and the data bus through connector J12. Two +24VDC fans are also powered through J12.

## Door Latches

J4 & J5

Door Latches are controlled by the microprocessor and the status of the Door Interlock circuit. Signals are driven by BTS428 High-Side Power Switches.

## Compressor and Fans

The Condenser fan J2, Compressor (wiring harness from relay), and the two +24V DC fans, J12, are controlled by the microprocessor. Signals are driven by BSP550 High-Side Power Switches.

## Rotor ID

Via J8

Index and Code pulses from the Hall Effect Sensor are filtered and connected to the microprocessors TPU12 and TPU10 channels

## Imbalance

Via J9

U36XZY

The imbalance circuit detects drive displacement. A flag, which is a grayscale image printed on a piece of transparent plastic, is mounted to a bracket that is attached to the drive. Any movement of the drive displaces the flag, which passes through a photo-interrupter. The circuit, biased at +2.5VDC, detects and holds the peak signal from the photo-interrupter. This value is fed to the A/D converter U25 where software determines if a gross imbalance is present.

## Keypad

Via J1

Keypad decoding is achieved with the common Row and Column technique.

## Display

Via J3

A vacuum fluorescent display, driven by the microprocessor, displays the instruments status and run parameters.

## Motor Driver Board

### General

The Motor Driver Board (MDB) provides the necessary power handling components to drive a three phase induction motor. These components can be organized into 5 sections: Power Supplies, Interface, Timing, IGBT Drive, Power Module, and Fault Detection. All circuits are referenced to the A.C. line input. Care should be exercised when connecting test equipment.

### Power Supplies

There are two power supply circuits: a high voltage power supply (HVPS), and a low voltage power supply (LVPS). The HVPS converts the rectified A.C. line voltage to 400 volts D.C. The supply has soft start, over voltage and over current protection. The major components of the HVPS are L4, C14 & 15, QF 24 & 27, and U22. The LVPS converts the 400 volt output of the HVPS to +5 and +15 volts D.C. for use on the MDB. The major components of the LVPS are T1 and U15.

### Interface

Control and status signals are communicated between the Motor Driver Board and the Control Board via opto-isolators located on the MDB. The inputs to the MDB are three digital pulse width modulated (PWM) signals for controlling motor current, drive enable for energizing the IGBT drive, brake, and fault clear (U5, 8, 9, 14, 17 & 18). The output signals are drive fault, drive on, over temperature, and an analog voltage of the 400 volt supply referenced to logic ground (U6, 23, 24 & 25).

### Timing

Components U2 and 19 delay the activation of the IGBT drivers to insure that the high side drive does not conduct while the low side is still on. The delay is in the order of 1.2 micro-seconds.

### IGBT Drive

U20 translates the 5 volt level PWM signals to 400 volt amplitude. It provides the necessary gate drive voltages for the IGBT bridge and some fault detection. It also provides the gate drive voltage to drive a Brake Drive IGBT.

## Section 4: Schematics

### Power Module

The Power Module contains six IGBTs forming a three-phase bridge circuit, a Brake Drive IGBT, a full wave bridge rectifier, and a thermistor for monitoring heat sink temperature.

### Fault Detection

Besides the fault detection provided by the IGBT driver, the current through the IGBT bridge is monitored by U12 & 13. If the current should exceed 20 amperes the drive fault signal will activate, disabling the IGBT drive. Also the thermistor within the power module is monitored and the fault signal activated if the maximum temperature of the module is exceeded. The drive over temperature status line is also activated.

### Indicators

There are three LED indicators on the MDB. LD1 is green and indicates that the drive is enabled. LD2 is red and indicates that the fault signal is active. LD3 is yellow and indicates that high voltage is present. It should be noted that dangerous voltages are present on the MDB while LD3 is illuminated. It will remain illuminated after power is removed until the HVPS discharges.

### Normal Operation

Before a run is made, only the yellow LED is illuminated. When the run begins both the yellow and green LED's are illuminated. The green LED is extinguished at the end of the run. The red LED should never be illuminated. Also, the Brake resistor will get hot during deceleration and is electrically connected to the HVPS. Therefore contact with the Brake Resistor should be avoided.

THIS DOCUMENT CONTAINS PROPRIETARY INFORMATION OF BECKMAN INSTRUMENTS, INC. AND IS TENDERED SUBJECT TO THE CONDITIONS THAT THE INFORMATION (A) BE RETAINED IN CONFIDENCE, (B) NOT BE REPRODUCED OR COPIED IN WHOLE OR IN PART AND (C) NOT BE USED OR INCORPORATED IN ANY PRODUCT, EXCEPT UNDER AN EXPRESS WRITTEN AGREEMENT WITH BECKMAN INSTRUMENTS, INC.

CHG.	E.O.NO.	DATE	BY	CHK
AA				
AB	42118	3/23/04	CWB	SC
AC	42147	4/9/04	CWB	SC
AD	42181	5/14/04	CWB	JW
AE	42198	6/10/04	CWB	

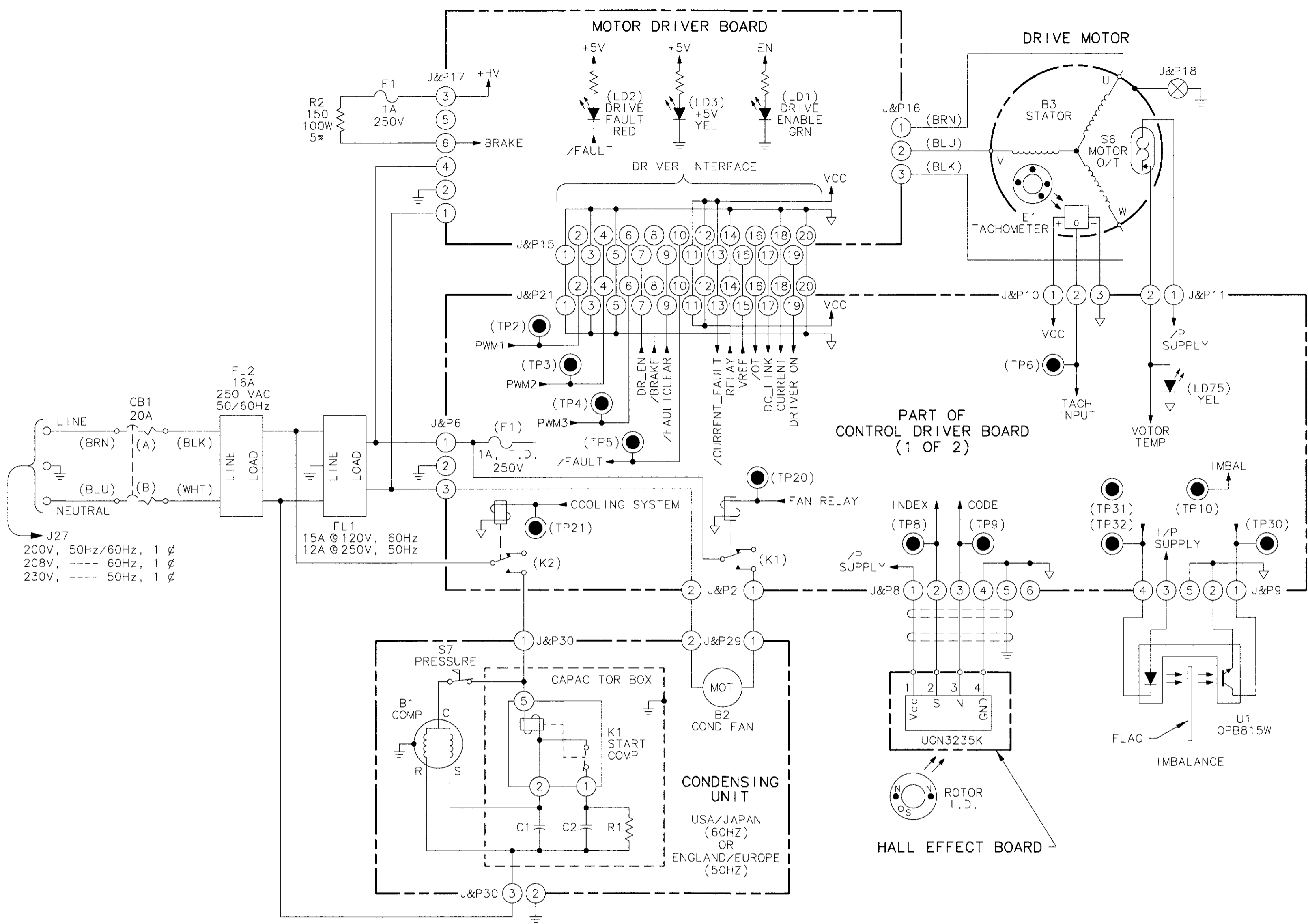

5. ⚡ DENOTES NOISY (EARTH, DIGITAL) GROUND.  
 4. RESISTOR AND HEATER VALUES ARE IN OHMS.  
 3. CAPACITOR VALUES ARE IN MICROFARADS.  
 2. CIRCUIT SHOWN DE-ENERGIZED.  
 1. REFERENCE DOCUMENTS:  
 SCHEMATIC, CONTROL DRIVER BOARD - 392961-01  
 SCHEMATIC, MOTOR DRIVER BOARD --- 392450-02  
 SCHEMATIC, HALL EFFECT BOARD --- 367960-06  
 WIRING DIAGRAM ----- 392962

NOTES: (UNLESS OTHERWISE NOTED)

LAST REF DESIG USED

B5	F1	P33	CN1
C2	FL2	R2	
CB1	J33	RT1	
DS1	K1	S7	
E1	L2	U1	

BY	DATE	<b>BECKMAN</b> <small>BECKMAN INSTRUMENTS INC.          SPINCO DIVISION          1050 PAGE MILL ROAD          PALO ALTO, CALIFORNIA 94304</small>
DR C.W. BROWN	3/1/04	
CHK J.WILLIAMS	3/12/04	
ENGR J.MURPHY	3/12/04	
TITLE		SCHEMATIC, OVERALL ALLEGRA X-15R
(A)		
C SIZE	CODE IDENT NO. <b>07978</b>	DWG NO. <b>392961-00</b>
MOD ALLEGRA X-15R		SCALE --- 1st USE: 392930 SHEET 1 OF 2

392961-00  
DWG. NO.

C  
SIZE

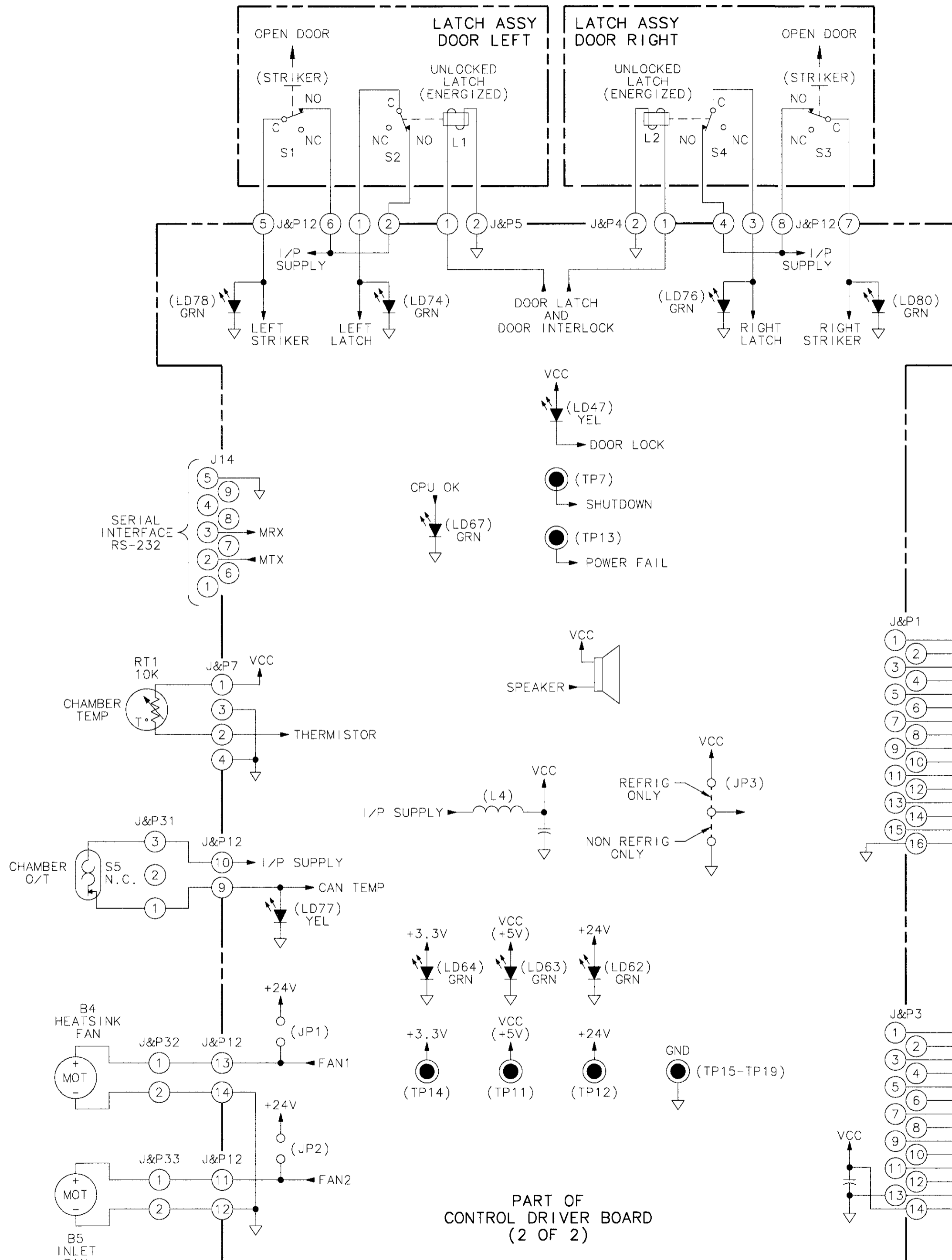

PART OF CONTROL DRIVER BOARD (2 OF 2)

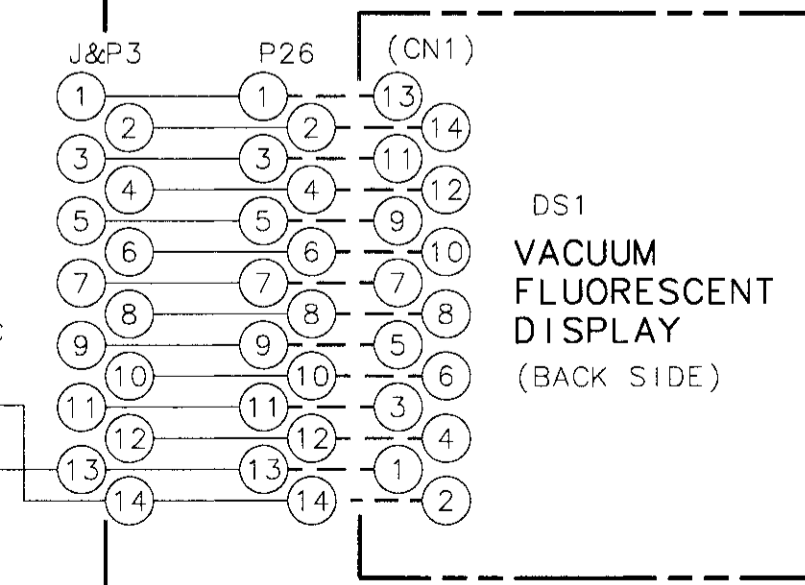
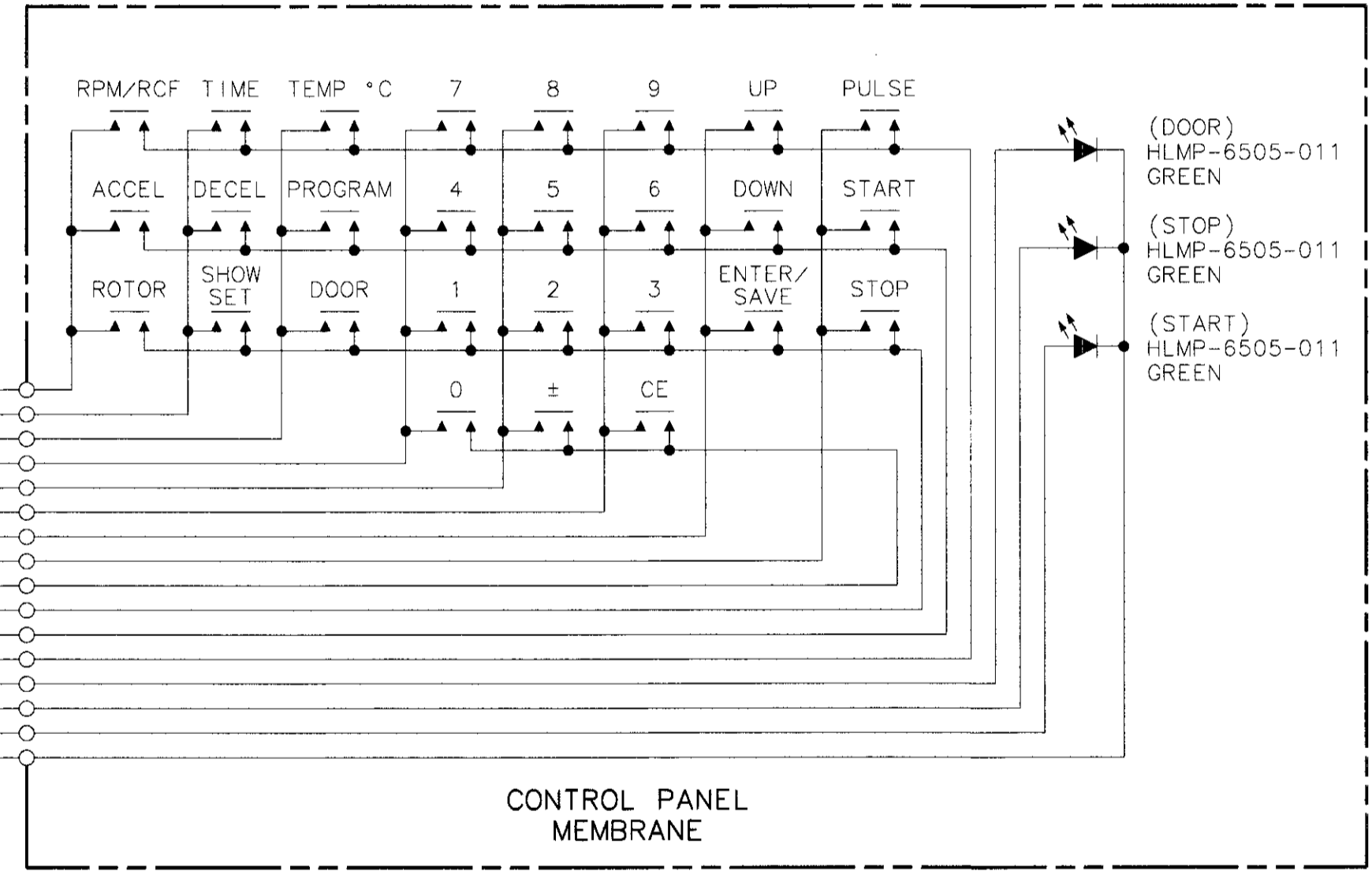

<b>BECKMAN</b>		BECKMAN INSTRUMENTS INC. SPINCO DIVISION 1050 PAGE MILL ROAD PALO ALTO, CALIFORNIA 94304	
C SIZE	CODE IDENT NO.	DWG NO.	
	07978	392961-00	
SCALE		1st USE	SHEET 2 OF 2

392961-00 DWG NO

C SIZE



ALLEGRA X-12/R, X-15R

RED BOOK SERVICE PARTS LIST

ISSUED 9/28/04

ELECTRONICS	2
DRIVE SYSTEM	2, 3
REFRIGERATION	3
DOOR ASSEMBLY	3
MISCELLANEOUS	4
ROTOR SUPPLY LIST	4
Allegra X-12R 208V/ 60 Hz	392302
Allegra X-12R 200V/ 50/60 Hz	392303
Allegra X-12R 230V 50 Hz	392304
Allegra X-12 208V/ 60 Hz	392472
Allegra X-12 200V/ 50/60 Hz	392473
Allegra X-12 230V 50 Hz	392474
Allegra X-15R 208V/ 60 Hz	392932
Allegra X-15R 200V/50/60 Hz	392933
Allegra X-15R 230V 50 Hz	392934

Allegra X-12/R, X-15R  
Replacement Parts List

**ELECTRONICS**

	<b>All</b>	<b>X-15R only</b>
Board Assy, P.W. System Ctrl. Bd	392453(X-12R) 392740(X-12)	392963
Board Assy, P.W. Motor Driver Board	<del>392375</del> 393289	
Fuse Holder, Brake	869899	
Fuse 1A	8395	
Relay K1	979842	
Relay K2	979852	
Brake Resistor	A09041	
Cable Driver Interface	392460	
Cable, VFD	392459	
Circuit Breaker	A09122	
Display VFD	392741	
EMI Filter	A09068	
Second EMI Filter		A18788
Fan, DC	392469	
Fan, heatsink	392454	
Harness, AC	392458	
Harness, DC	392456	392994
Harness refrigeration	392461	
Imbalance, Switch Assy optical	392467	392955
Keypad	392377	
Module Power Inlet	964643	
Switch Plunger, (Striker X-15R)	979485	A15801
Switch Sensitive, (Latch X-15R)	978999	A13385
Solenoid, Latch (X-15R)		392996
Thermistor	392372	
Thermostat, OT	369103	
Power Cord 208V	364184	
Power Cord 230V	964654	

**DRIVE ASSEMBLY**

Drive Motor Assembly	392357	392914
Boot, Bowl	392356	
Ferrule, Drive Shaft	392361	
Flag Optical	392429	392903
Grommet, Motor Mounting	349786	
Housing Assy, Rotor ID	392352	392916
Lock-Nut, Motor Mounting	829294	
Mounts, Compression (orange)	392427	
Mounts, Screws	964964	
Mounts, Washer	979564	
Mount Shock, Sandwich		392997
Nut, M5 Motor Mount		964847
Nut, Sandwich Mount		885321
Ring mount, Motor (molded)	367218	
Screw, Rotor ID	979177	
Screw, Motor Mount	948159	

Allegra X-12/R, X-15R  
Replacement Parts List

**DRIVE ASSEMBLY**

All

X-15R only

Spacer, Rotor ID	979225	A17712
Spacer, Motor Tie down		393000
Tach Sensor	A16477	
Washer, Flat, Mounting	878492	
Washer, Motor, M5		A16113
Washer, Sandpaper		961811

**REFRIGERATION**

Bowl, refrigerated	392387	393007
Compressor Unit 208Vac 50/60Hz, R404a	392398	393012
Compressor 208V	A12630	
Compressor Unit 230Vac 50Hz , R404a	392399	393013
Compressor 230V	A12631	
Capacitor Box 60 Hz	A12300	
Capacitor Box 50 Hz	A12301	
Motor, Fan 60 Hz	A12298	
Motor, Fan 50 Hz	A12299	
Blade, Fan,	A12302	
Shrader Valve	979018	
Thermistor, Nut	885317	
Thermistor O-Ring	42550	
Pressure Control Valve	A13097	

**DOOR ASSEMBLY**

Door Assy	392320	392950
Striker, Door Lock	392435	392948
Striker, Nut	927746	868288
Striker, Washer	976094	
Hinge Assy, Door left	392318	
Hinge Assy, Door Right	392319	
Hinge spacer	393045	
Window, Strobe Port	358753	
Gasket, Strobe Port	362260	
Latch Assy (X-15R only)		392900
Latch Assy Door left	392329	
Latch Assy Door right	392330	
Gasket housing/ Door, inside	392396	393054
Gasket housing/ Door, outside	392397	393053
Gasket door, D Profile	392477	
Gasket door, Square profile	392894	
Tether, Door release		392998
Cord, Dacron	978139	



Allegra X-12/R, X-15R  
Replacement Parts List

MISCELLANEOUS

All

X-15R only

Cable Assy, Control Panel	392383	
Grommet Door Latch	392484	
Panel Front Control	392378	
Panel, Refrigeration Front	392384	
Foot	392344	
Tie Down Anchoring Kit	392482	392988
Screw M8, Tie Down		A16602
Strip D shape	A12045	

Rotors

SX4750 w/o bucket covers	369702	
Yoke only	393074	
Tie Down Assy	369716	
Buckets Set of 2	392804	
Covers, Set of 2	392805	
Bucket O-ring (pkg/8)	961648	
μ Plate Carriers for SX4750, Set of 2	392806	
Carriage Assembly Repl. kit, set of 2	392873	
Covers for μ Carriers, Set of 2	392807	
μ Plate, Pad replacement, set of 4	392872	
μ Plate, Gasket Repl., Set of 4	392812	
SX4750A Rotor Assembly	369704	
Yoke only	393073	
Tie Down Assy	369718	
FX6100 Rotor Assembly	369735	
Lid Assy	369738	
Large O-ring	870612	
Small O-ring	010179	

NOTES: (UNLESS OTHERWISE NOTED)

1. REF TEST SPECIFICATIONS 392959 (ALLEGRA X-15R).  
REF OVERALL SCHEMATIC 392961-00.  
REF WIRING DIAGRAM 392962.

2. SEE TABULATION FOR APPROPRIATE NAME RATING PLATE (ITEM 10, 11 OR 12).

3. LABEL (PART OF ITEM 10, 11 OR 12) TO BE PLACED ON REAR LEFT HAND SIDE OF DOOR IN AREA SHOWN. LABEL TO HAVE SAME SERIAL NUMBER AS ON PLATE (ITEM 10, 11 OR 12).

4. SECURE KNOT WITH DROP OF ADHESIVE (ITEM 206). INSERT GROMMET (ITEM 159) BETWEEN CORDS (ITEM 116). SECURE GROMMET INTO BUSHING (ITEM 197).

5. REFRIGERATION SYSTEM (ITEM 19 OR 20) TO BE FILLED WITH 20 OZ BY WEIGHT, OF REFRIGERANT R404A (ITEM 210).

6. APPLY ADHESIVE (ITEM 206) SPARINGLY TO BOTTOM SURFACE OF GROMMET (ITEM 111) PRIOR TO INSTALLATION.

7. TIGHTEN ALL THREE SCREWS (ITEM 131) UNIFORMLY TO 50 ± 5 IN-LB.

8. APPLY SILICONE RTV (ITEM 205) INSIDE THE GROOVE OF BOOT (ITEM 96), PRIOR TO MOUNTING TO BOWL (PART OF ITEM 95).

9. QUANTITIES IN PARENTHESIS "( )" ARE REFERENCE ONLY. PARTS COME FROM JIT KITS 392949 OR 392995.

10.

11. POSITION SPLICES OF GASKETS (ITEMS 98, 99, 100) IN REAR OF CENTRIFUGE. SPLICES MUST NOT OVERLAP.

12. APPLY ONE DROP OF ADHESIVE (ITEM 206) TO BUSHING (ITEM 197) PRIOR TO INSERTION INTO BASE (ITEM 42).

13. AFTER INSTALLATION OF GROMMET (ITEM 111), CLIP PULL TABS OF GROMMET FLUSH TO .05 PROTRUDED WITH UNDERSIDE OF ENCLOSURE WELDMENT (ITEM 45). APPLY LIGHT FILM OF VACUUM GREASE (ITEM 211) TO UNDERSIDE OF GROMMET FLAPS.

14. APPLY ONE DROP OF ADHESIVE (ITEM 207) TO THREAD OF SCREW (ITEM 131) PRIOR TO INSTALLATION INTO MOUNTS (ITEM 93).

15. REFER TO TEST SPECIFICATION 392959 FOR FINAL POSITIONING.

16. TETHER (ITEM 116) SHOULD HAVE .01-.04 GAP BETWEEN NUTS (ITEMS 166 & 167).

17. ADD SPACERS (ITEM 107) TO HINGE ASSY (ITEM 103 & 104) AS REQUIRED TO MAINTAIN DOOR HOLDING FORCE PER TEST SPEC. 392959.

18. APPLY ONE DROP OF LOCTITE (ITEM 174) TO THREADS OF STUDS (ITEM 106) PRIOR TO INSTALLATION.

THIS DOCUMENT CONTAINS PROPRIETARY INFORMATION OF BECKMAN INSTRUMENTS, INC. AND IS TENDERED SUBJECT TO THE CONDITIONS THAT THE INFORMATION (A) BE RETAINED IN CONFIDENCE, (B) NOT BE REPRODUCED OR COPIED IN WHOLE OR IN PART AND (C) NOT BE USED OR INCORPORATED IN ANY PRODUCT, EXCEPT UNDER AN EXPRESS WRITTEN AGREEMENT WITH BECKMAN INSTRUMENTS, INC.

CHG.	E.O.NO.	DATE	BY	CHK
AA				
AB	42192	6/3/04	CWB	HT
AC	42254	07-23-04	HT	SC
AD	42493	5-17-05	SC	JW
AE	42524	8-8-05	SC	JW
AF	42554	8-31-05	SC	JW
AG	42638	1-10-06	BC	CWB
AH	42710	4-28-06	SC	CWB
AJ	42715	6-29-06	SC	CWB
AK	42723	7-21-06	SC	DS
AL	42746	8-2-06	SC	CWB

392930

C

BY	DATE	<b>BECKMAN</b> <small>BECKMAN INSTRUMENTS INC.          SPINCO DIVISION          1555 PAGE MILL ROAD          PALO ALTO, CALIFORNIA 94304</small>
DR HIEP TRAN	02-02-04	
CHK <b>C.W. BROWN</b>	04/26/04	
DSGN HIEP TRAN	04/27/04	
ENGR B. CARSTENS	04/27/04	
TITLE		TABULATION, CENTRIFUGE ASSEMBLY
C SIZE	CODE IDENT NO. 07978	DWG NO. 392930
MOD ALLEGRA X-15R	SCALE ---	1st USE --- SHEET 1 OF 8

THIS DOCUMENT CONTAINS PROPRIETARY INFORMATION OF BECKMAN INSTRUMENTS, INC. AND IS TENDERED SUBJECT TO THE CONDITIONS THAT THE INFORMATION (A) BE RETAINED IN CONFIDENCE, (B) NOT BE REPRODUCED OR COPIED IN WHOLE OR IN PART AND (C) NOT BE USED OR INCORPORATED IN ANY PRODUCT, EXCEPT UNDER AN EXPRESS WRITTEN AGREEMENT WITH BECKMAN INSTRUMENTS, INC.

CHG.	E.O.NO.	DATE	BY	CHK
AL		SEE SHEET 1		

QTY	ZONE	ITEM	PART NO.	DESCRIPTION		
			40			
			39			
			38			
			37			
			36			
1	1	1	A12	35	456025	LABEL, HIGH VOLTAGE
1	1	1	A12	34	455771	LABEL, CAUTION - INT. MAINT
1	1	1	A12	33	455770	LABEL, DISCONNECT POWER
2	2	2	C11	32	392902	LABEL, PRESS HERE TO CLOSE
1	1	1	D4	31	393001	LABEL, IMBAL CALIBRATION
1	1	1	A12	30	A33233	LABPCE, MULTI COMPLIANCE NON-IVD
1	1	1	A12	29	369430	LABEL, SOFTWARE LICENSE, OPERATING SYSTEM
1	1	1	A12	28	393082	LABEL, REFRIGERANT R404A
				27		
				26		
				25		
				24		
				23		
1	1	1	A7,A14	22	392939	CONTROL PANEL ASSY, ALLEGRA X-15R
				21		
				20	393013	REFRIGERATION-COMPRESSOR ASSY, ENGLAND/EUROPE
				19	393012	REFRIGERATION-COMPRESSOR ASSY, USA/JAPAN
				18		
				17		
				16		
				15		
				14		
				13		
				12	392945	PLATE, NAME RATING, 208V ALLEGRA X-15R
				11	392946	PLATE, NAME RATING, 200V ALLEGRA X-15R
				10	392947	PLATE, NAME RATING, 230V ALLEGRA X-15R
				9		
				8		
				7	392992	SHIP LIST, ALLEGRA X-15R 230V
				6	392991	SHIP LIST, ALLEGRA X-15R 200V
				5	392990	SHIP LIST, ALLEGRA X-15R 208V
				4		
				3	393061	PACKAGING, TIE DOWN
				2		
				1	392931	CENTRIFUGE ASSEMBLY, COMMON

AL AL AL AL AL AL AC AL AF AB AB 2 3 2 3 2 3 AB

392930  
DWG. NO.  
C  
SIZE

ALLEGRA X-15R 208V 60HZ 392932	ALLEGRA X-15R 200V, 50/60HZ 392933	ALLEGRA X-15R 230V 50HZ 392934	<p><b>BECKMAN</b> BECKMAN INSTRUMENTS INC. SPUNO DIVISION 1050 PAGE MILL ROAD PALO ALTO, CALIFORNIA 94304</p>	
TITLE			<p>TABULATION, CENTRIFUGE ASSEMBLY</p>	
C SIZE			CODE IDENT NO. 07978	DWG NO. 392930
MOD ALLEGRA X-15R			SCALE	1st USE SHEET 2 OF 8

THIS DOCUMENT CONTAINS PROPRIETARY INFORMATION OF BECKMAN INSTRUMENTS, INC. AND IS TENDERED SUBJECT TO THE CONDITIONS THAT THE INFORMATION (A) BE RETAINED IN CONFIDENCE, (B) NOT BE REPRODUCED OR COPIED IN WHOLE OR IN PART AND (C) NOT BE USED OR INCORPORATED IN ANY PRODUCT, EXCEPT UNDER AN EXPRESS WRITTEN AGREEMENT WITH BECKMAN INSTRUMENTS, INC.

CHG.	E.O.NO.	DATE	BY	CHK
AL	SEE SHEET 1			

		130			
	B8	129	1	340574	LABEL, ROTATION - ARROW
	C15	128	1	456024	LABEL, PROTECTIVE EARTH
		127			
	C10	126	1	392485	SHROUD, EMI FILTER
		125			
		124			
		123			
	A3	122	2	004595	CLAMP, CABLE, LOOP .50 NYLON
	B3	121	8	928450	CLAMP, CABLE, LOOP .75 NYLON
	B4	120	2	928449	CLAMP, CABLE, LOOP .50 NYLON
	B5	119	1	863201	CLAMP, PVC BLACK - 1/4
		118			
	A8, C6	117	1	392383	CABLE ASSY
16	A6, B5	116	2	392998	TETHER, DOOR RELEASE
	C6	115	1	392384	PANEL ASSY, REFRIG
		114			
AC	D3	113	A/R	A20315	STRIP, EPDM, PSA, D-SHAPE .50 W X.50 H
AB	B8	112	A/R	A12045	STRIP, EPDM RUBBER, D-SHAPE .375W
13 6	C7	111	2	392484	GROMMET, DOOR LATCH
		110			
		109			
	A8, C6, D5, D7.	108	2	392900	LATCH ASSY, DOOR
AB 17	C8	107	A/R	393045	SPACER, HINGE
AG	D7	106	1	393279	DOOR ASSY, WRAP AROUND
	D6, D7	105	2	392948	STRIKER, DOOR
	C8	104	1	392319	HINGE ASSY, DOOR RIGHT
	C8	103	1	392318	HINGE ASSY, DOOR LEFT
		102			
AB	D2, D3	101	1	393057	GASKET, FOAM BOWL
11	D8	100	1	392477	GASKET, DOOR - D PROFILE
AB 11	C7	99	1	393053	SEAL, ENCLOSURE - OUTER
AB 11	D2	98	1	393054	SEAL, ENCLOSURE - INNER
		97			
8	C3, D1	96	1	392356	BOOT, BOWL
AB 8	B1, C3, C6, D1	95	1	393007	FOAMED BOWL ASSY, SIDE COILS
AJ		94			
AJ	B4	93	3	393275	KIT, MOUNT ASSEMBLY
	B3, B14, B15	92	1	392923	DRIVE ASSY
		91			
		90			
		89			
AB AJ		88			
AJ		87			
AJ		86			

AJ		85			
AJ		84			
AB AJ		83			
AJ		82			
AB AJ		81			
		80			
		79			
AE	D12	78	A/R	6002323	ADHESIVE, 3M NO. 77
	A4	77	1	008395	FUSE, NON-TIME DELAY 1A, 250V
	A4, B15	76	1	869899	FUSE HOLDER, PANEL MOUNT - 250V
	B8	75	1	A09122	CIRCUIT BREAKER - 2 POLE, 20A
	B4, C1	74	1	392918	FLAG ASSY
	A4, B15, C1	73	1	392955	SENSOR ASSY, OPTICAL
AJ		72			
	B15, C4	71	1	392469	FAN ASSEMBLY, DC
AB	A12, D14	70	1	393009	ELECTRICAL PANEL ASSY
AE	D12	69	A/R	3003003	ALUM STRIP, .005THK
AE	D12	68	A/R	6002501	ADHESIVE, SLNT - GRY/GRN
AE	D12	67	1	369103	THERMOSTAT ASSY
AE	D11	66	1	042550	O-RING, BUNA-N 120 .364ID X .05 OD
AE	C11	65	1	885317	NUT, HEX - 0.375-32 NYL NATURAL
AE	D12	64	1	392372	THERMISTOR ASSY 10K
9	B15	63	(1)	392457	JUMPER, MOTOR
9	B15	62	(1)	392466	HARNESS, DRIVER BOARD POWER
AB 9	B14, D15	61	(1)	393011	HARNESS AC
9	B5	60	(1)	392994	HARNESS DC
AB 9	B3, C15	59	(1)	393056	CABLE, GROUND STRAP
9	(NOT SHOWN)	58	1	392995	J.I.T. KIT HARNESS
		57			
		56			
		55			
	A3	54	6	358798	FOOT, (SCD)
	A3	53	12	392385	SPACER, FOOT
		52			
	D4	51	4	392492	BRACKET, BARRIER
	C7	50	2	392748	BRACKET, PANEL, REFRIGERATION
	A7	49	2	392747	BRACKET, PANEL, FRONT
	A4	48	1	392729	BRACKET, FUSE
		47			
		46			
AJ 9	D9	45	(1)	393500	ENCLOSURE ASSY
AB 9	B15, D2, D4	44	(1)	393055	BARRIER WELDMENT, CHAMBER
AH		43			
AH 9	A3, B5, C1, C16	42	(1)	393494	BASE, ASSEMBLY
9	(NOT SHOWN)	41	1	392949	J.I.T. KIT MECHANICAL

ZONE	ITEM	QTY	PART NO.	DESCRIPTION
CENTRIFUGE ASSY, COMMON 392931				
<b>BECKMAN</b>				BECKMAN INSTRUMENTS INC. SPINCO DIVISION 1050 PAGE MILL ROAD PALO ALTO, CALIFORNIA 94304
MODEL ALLEGRA X-15R		SCALE ---	1st USE ---	SHEET 3 OF 8

392930  
DWG. NO.

C  
SIZE

THIS DOCUMENT CONTAINS PROPRIETARY INFORMATION OF BECKMAN INSTRUMENTS, INC. AND IS TENDERED SUBJECT TO THE CONDITIONS THAT THE INFORMATION (A) BE RETAINED IN CONFIDENCE, (B) NOT BE REPRODUCED OR COPIED IN WHOLE OR IN PART AND (C) NOT BE USED OR INCORPORATED IN ANY PRODUCT, EXCEPT UNDER AN EXPRESS WRITTEN AGREEMENT WITH BECKMAN INSTRUMENTS, INC.

CHG.	E.O.NO.	DATE	BY	CHK
AL	SEE SHEET 1			

	220				
	219				
	218				
	217				
	216				
	215				
	214				
	213				
	212				
13	C7	211	A/R	6500201	GREASE, VAC, SILICONE
AB 5	C2	210	20oz	7028118	REFRIGERANT R404A
	209				
	B1	208	A/R	4007106	SOLDER, SILVER ALLOY - .125 W, .05 THK
14	C4	207	A/R	6000106	ADHESIVE, LOCTITE-242 - BLU
4 12 6	A5, C7	206	A/R	6000808	ADHESIVE, LOCTITE-416
8	D1	205	A/R	5302524	LIQ, SILI, RUBBER RTV 108 CLEAR
	204				
AC	A12, B7	203	A/R	A09797	SHIELD, EMI - .5 WD X .125 THICK
	D3	202	A/R	4522947	EXTN, PVC-BLK MOLDING, 3/16
	A1, B2	201	A/R	5504301	TAPE, CLOTH 1/8 THK
AB		200			
		199			
		198			
12	A5, B5	197	1	870761	BUSHING, SNAP -.375 ID, NYLON
		196			
	A8	195	2	964823	HINGE, BUTT - 2LG X 2W CRES
		194			
		193			
		192			
	B2	191	4	964612	STANDOFF, INSULATOR - .5 OD X .5LG NYLON BLK
		190			
	A4, C1	189	1	392903	FLAG, OPTICAL
		188			
AL	A7, C6	187	6	A29282	WASHER, FLAT, RET.- NO.10 .18 ID X .45 OD
		186			
	C4	185	3	961811	WASHER, SANDPAPER
	A6, C7	184	10	964880	WASHER, FLAT - M4 S-ZI
AJ		183			
AB	C15, D16	182	3	964920	WASHER, EXTERNAL - M6 SSTL ZINC
	C2	181	4	979689	WASHER, FLAT - M6
		180			
	B4	179	2	808252	WASHER, EXT. - #8 STL ZINC
	D6, D7	178	2	976094	WASHER, FLAT - 3/8 S-ZI
	C3	177	1	828590	WASHER, EXTERNAL - #8 STL BLK ZINC
	C4	176	3	827385	WASHER, FLAT - 5/16 SS
ZONE	ITEM	QTY	PART NO.	DESCRIPTION	
CENTRIFUGE ASSY, COMMON 392931					

	A2	175	4	802186	WASHER, SPLIT, 1/4, STL ZINC
AD	C8	174	A/R	6000106	LOCTITE, MEDIUM STRENGTH
		173			
		172			
AJ		171			
	D6, D7	170	2	868288	NUT, HEX .375-24 CRES PSVT
	C2	169	4	964788	NUT, M6 NYLOC
AB	B8, C15, C4, C8, D16	168	27	961735	NUT, M6 SLFLKG
16	A6	167	2	889805	NUT, 6-32 ACORN CRES
16	A6	166	2	024687	NUT, 6-32 SLFLKG STL ZINC
AC	A3, A8, D6	165	8	964847	NUT, M5 SLFLKG
		164			
	C3	163	1	861132	NUT, M4X0.7 STL
AJ		162			
		161			
		160			
4	A5, B5	159	1	040889	GROMMET
		158			
		157			
AJ		156			
		155			
		154			
	A2	153	4	A10364	SCREW, M6X1.0 X 35mm HEX S ZINC
		152			
		151			
	B4, D4	150	25	964630	SCREW, HXFLG - M6 x 20mm S ZINC
	A12	149	6	964855	SCREW, HXFLG - M6 X 12mm
		148			
	A3	147	6	A16400	SCREW, CAP - M6X1.0 X 35mm S BLK HXSO
	C3	146	3	A08781	SCREW, SET, M5 X 30mm S BLK HXSO CP
AH AC	A4	145	2	978372	SCREW, HXFLG - M5X0.8 X 16mm S ZI
AL	A7, C6	144	6	A28470	SCREW, MACH, M5X0.8X16 PHIL CRES
AJ AC	B3	143	2	964885	SCREW, HXFLG M5 x 12mm
AJ	A8, A12, B8, C4	142	23	978101	SCREW, HXSO BU M5 X 10mm SS
	C6	141	1	A08790	SCREW, HXFLG M5X0.8 X 10mm S-BLK
AJ AH AC	A7	140	1	979691	SCREW, HXFLG M5 x 8MM
	A8	139	8	A10363	SCREW, M5 x 10mm FL 90° PHIL SS
		138			
AJ AB	B3	137	10	A19870	RIVET, SNAP, NYL BLK, .197SHK .217-.256PNL
AJ		136			
	B4, B6	135	6	964870	SCREW, HXFLG M4 X 10mm S ZN YEL
	A6, C7	134	10	978440	SCREW, MACH PAN HD, M4 X 10mm SS
		133			
		132			
7	C4	131	3	848549	SCREW, HEX HEAD 5/16-18 X 3/4 S ZINC
ZONE	ITEM	QTY	PART NO.	DESCRIPTION	
CENTRIFUGE ASSY, COMMON 392931					
MODEL ALLEGRA X-15R				SCALE --- 1st USE --- SHEET 4 OF 8	

392930 DWG. NO.

C SIZE

CENTRIFUGE ASSY, COMMON 392931		<b>BECKMAN</b>		BECKMAN INSTRUMENTS INC. SPINDLE DIVISION 1050 PASE MILE ROAD PALO ALTO, CALIFORNIA 94304	
C SIZE	CODE IDENT NO. 07978	DWG NO. 392930			

THIS DOCUMENT CONTAINS PROPRIETARY INFORMATION OF BECKMAN INSTRUMENTS, INC. AND IS FURNISHED SUBJECT TO THE CONDITIONS THAT THE INFORMATION IS TO BE KEPT SECRET AND NOT BE REPRODUCED OR COPIED IN WHOLE OR IN PART AND THAT IT IS TO BE USED OR INCORPORATED IN ANY PRODUCT (EXCEPT AS EXPRESSLY WRITTEN AGREEMENT) WITH BECKMAN INSTRUMENTS, INC.				
CHG.	E.O. NO.	DATE	BY	CHK
AL				SEE SHEET 1

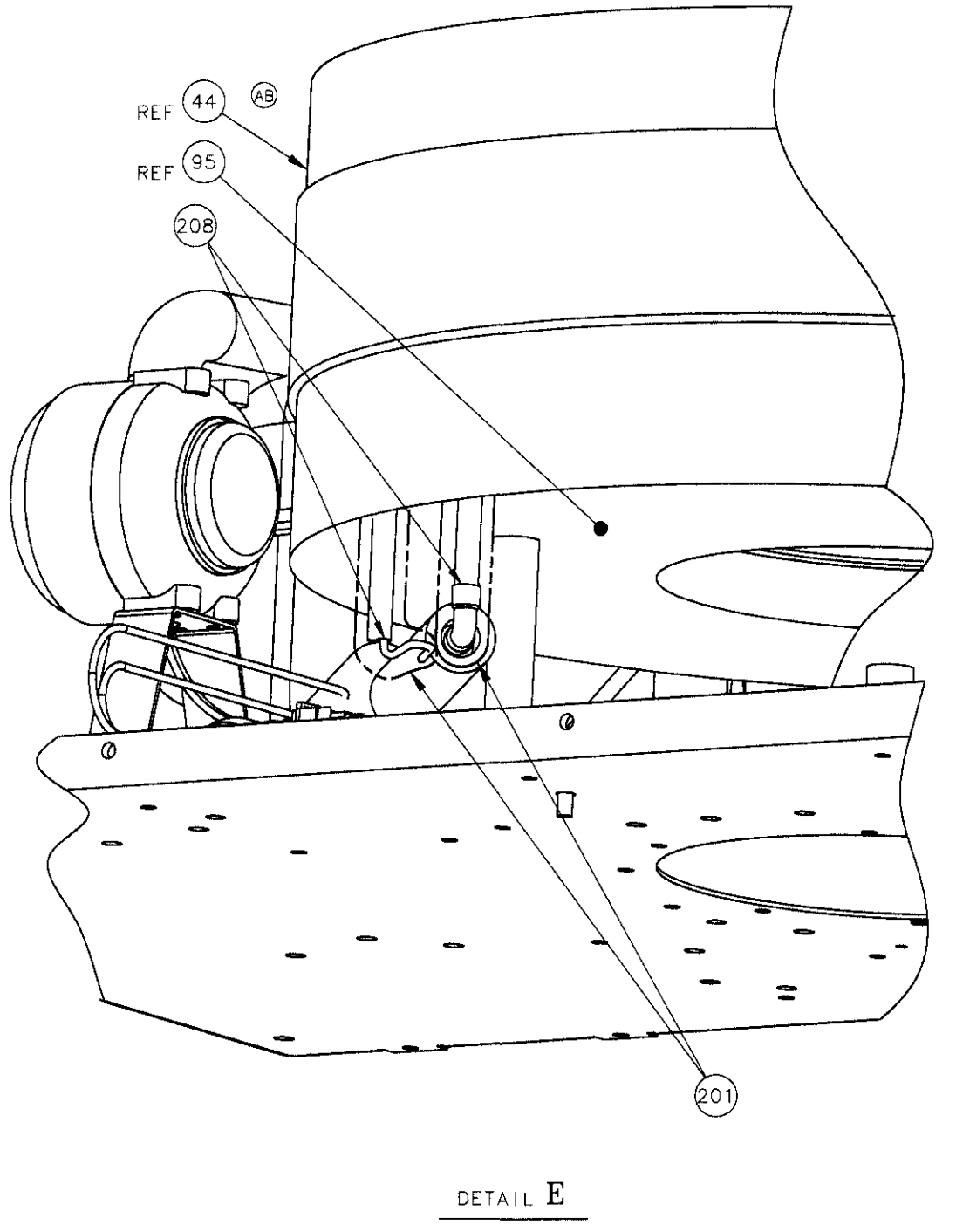
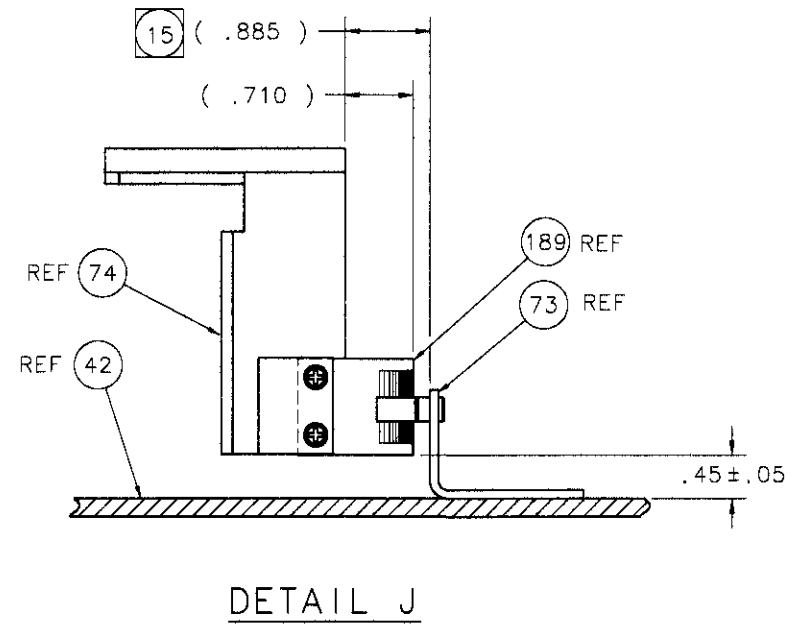
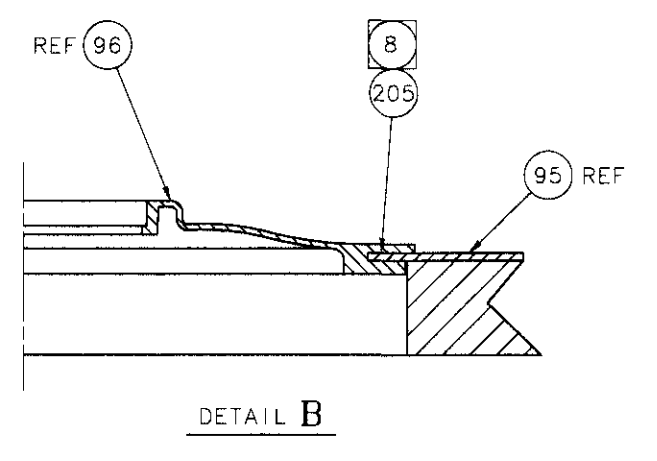
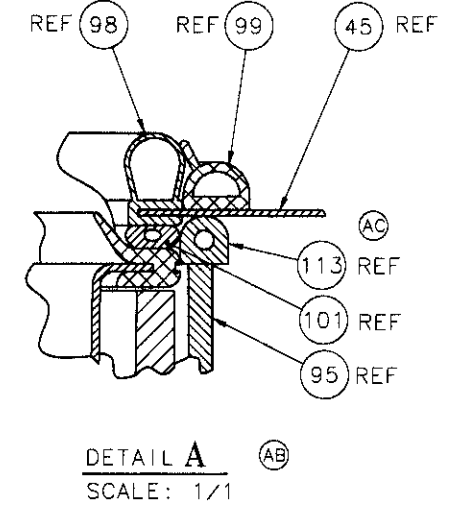
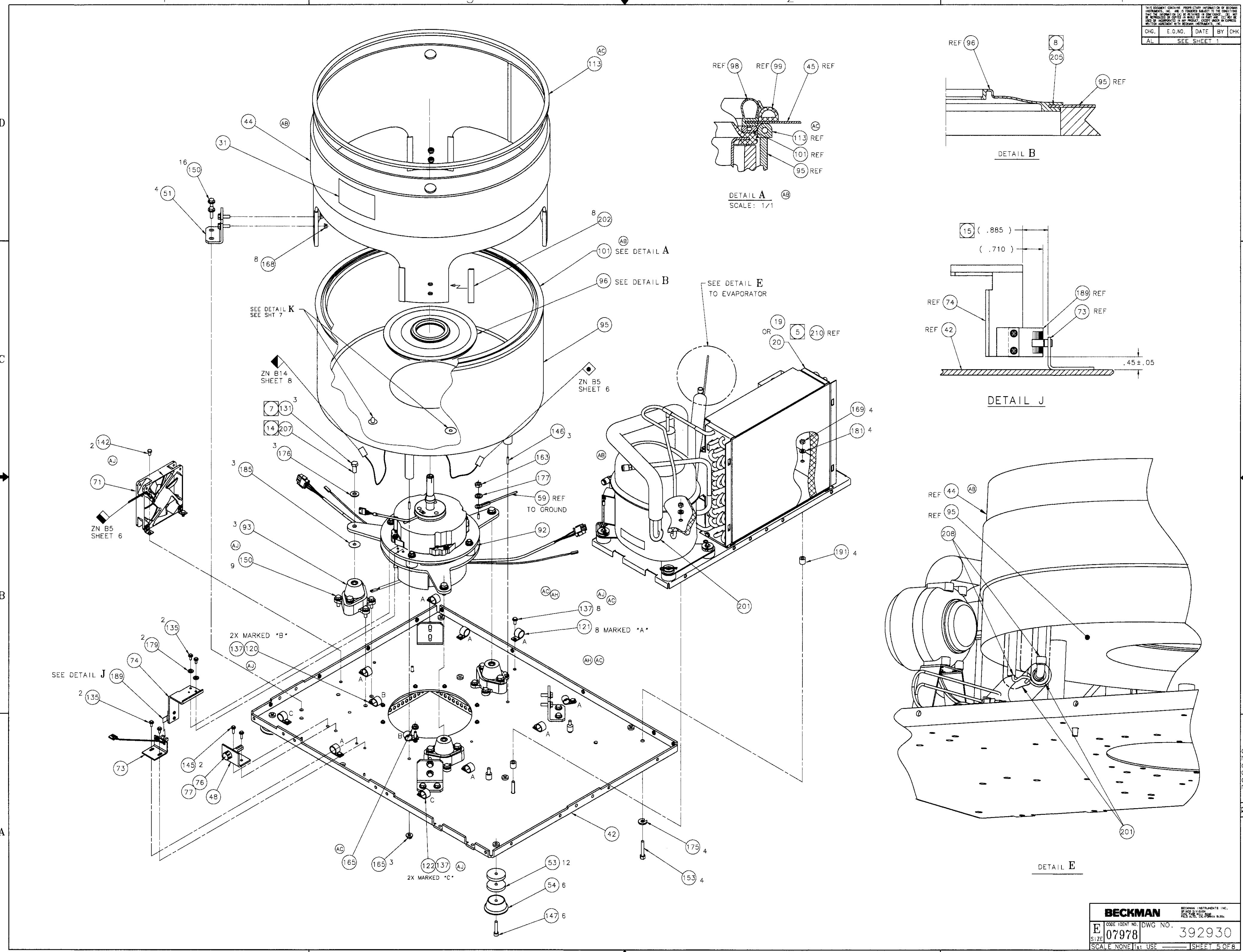





THIS DOCUMENT CONTAINS PROPRIETARY INFORMATION OF BECKMAN INSTRUMENTS, INC. AND IS FURNISHED SUBJECT TO THE CONDITIONS THAT THE RECIPIENT OR USER SHALL NOT REPRODUCE, COPY, OR DISSEMINATE IT IN ANY MANNER WITHOUT THE EXPRESS WRITTEN AGREEMENT OF BECKMAN INSTRUMENTS, INC.				
CHK.	E.O.NO.	DATE	BY	CHK
AL				SEE SHEET 1

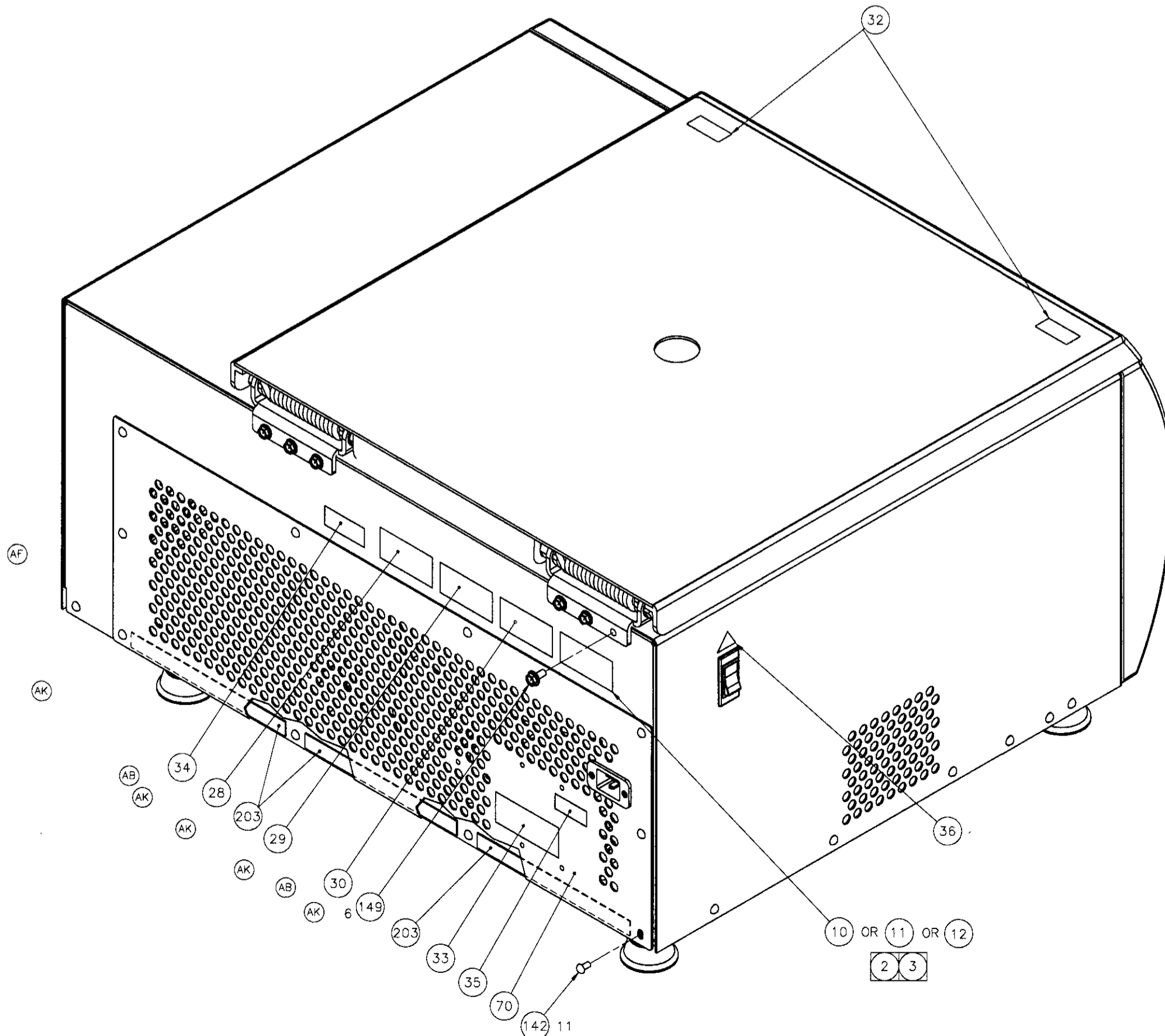
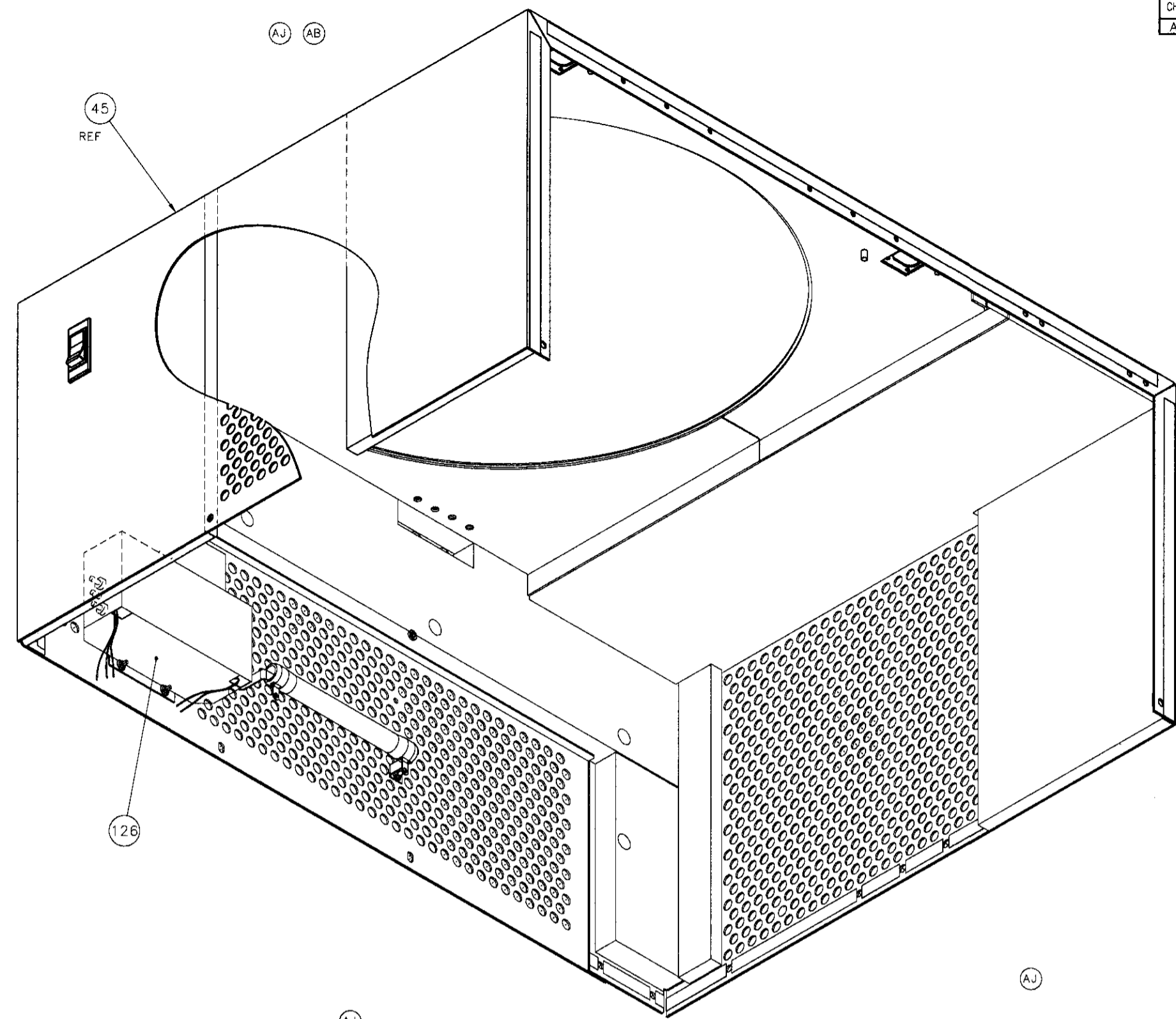
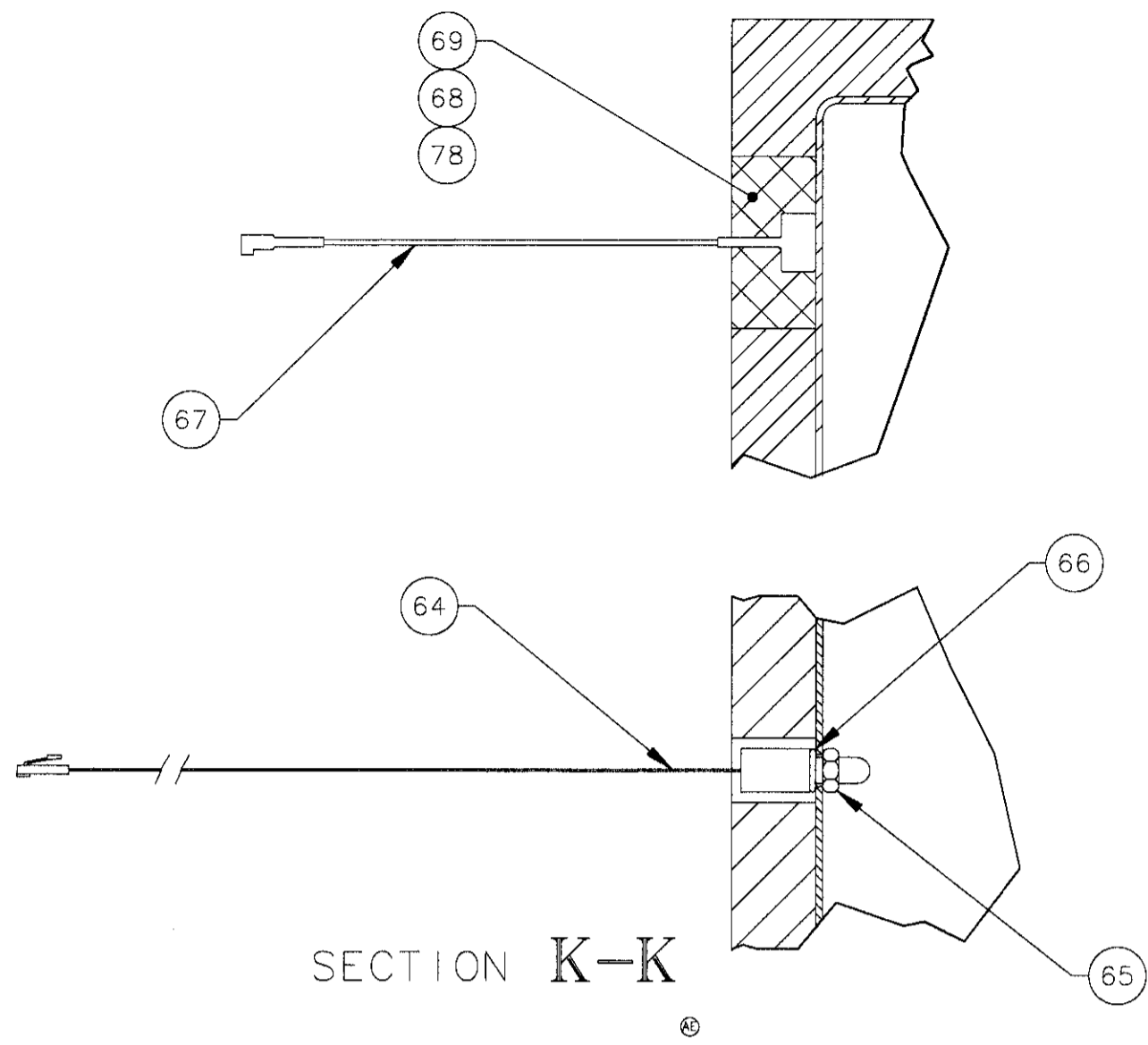

**BECKMAN** BECKMAN INSTRUMENTS, INC.  
 E CODE IDENT NO. DWG NO. 392930  
 SIZE 07978  
 SCALE NONE USE SHEET 7 OF 8



THIS DOCUMENT CONTAINS PROPRIETARY INFORMATION OF BECKMAN INSTRUMENTS, INC. AND IS SUBJECT TO THE CONDITIONS THAT THE INFORMATION IS TO BE KEPT IN CONFIDENCE. IT IS NOT TO BE REPRODUCED OR COPIED IN WHOLE OR IN PART AND IT IS NOT TO BE USED OR INCORPORATED IN ANY PRODUCT, EXCEPT UNDER AN EXPRESS WRITTEN AGREEMENT WITH BECKMAN INSTRUMENTS, INC.				
CHG.	E.O. NO.	DATE	BY	CHK
AL				SEE SHEET 1

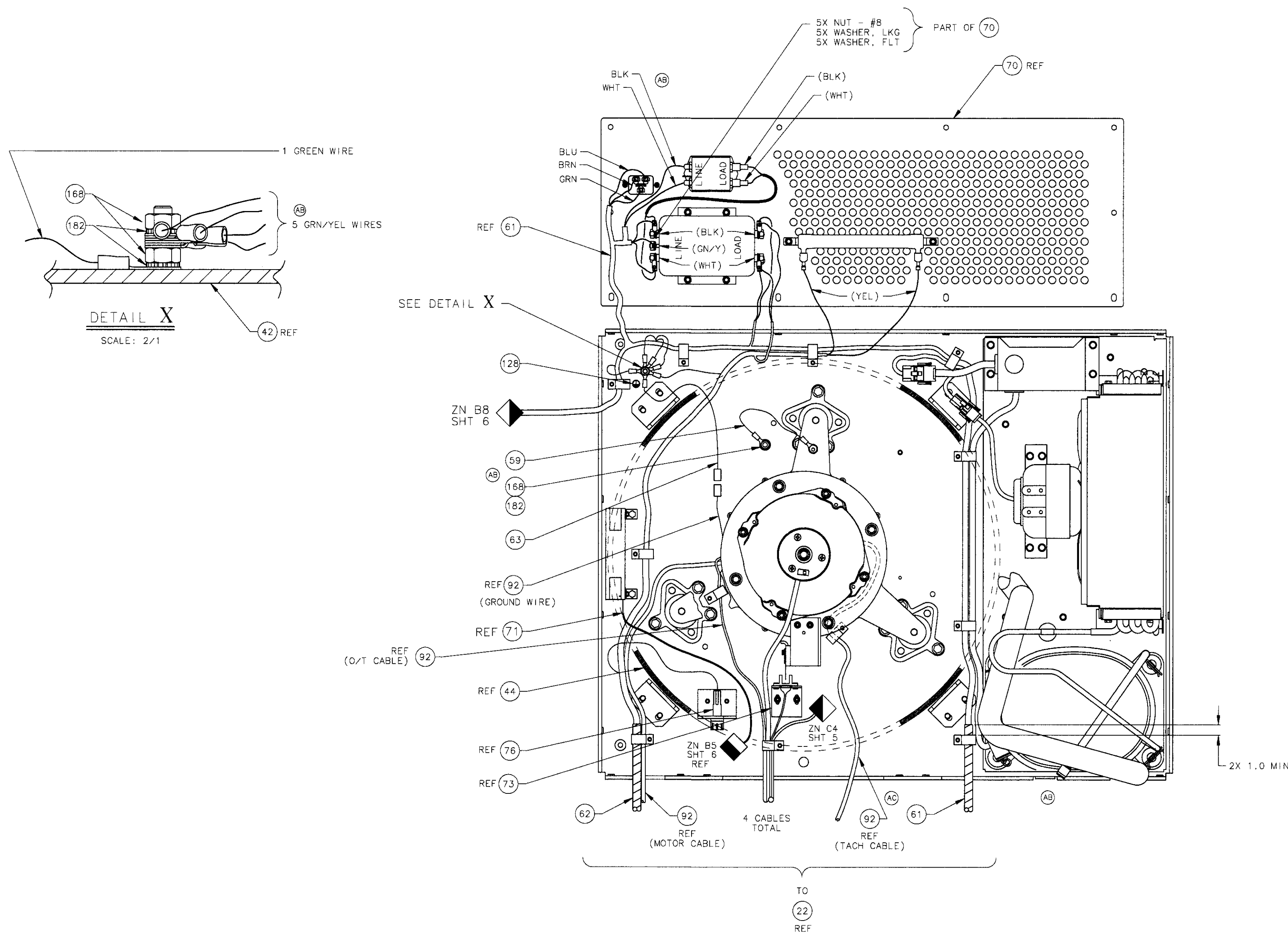

CABLE AND HARNESS ROUTING

<b>BECKMAN</b>		BECKMAN INSTRUMENTS INC.	
CODE IDENT NO.	DWG NO.	392930	
SIZE	07978	SCALE NONE 1st USE	
SHEET 8 OF 8		SHEET 8 OF 8	

E 392930

THIS DOCUMENT CONTAINS PROPRIETARY INFORMATION OF BECKMAN INSTRUMENTS, INC. AND IS TENDERED SUBJECT TO THE CONDITIONS THAT THE INFORMATION (A) BE KEPT IN CONFIDENCE, (B) NOT BE REPRODUCED OR COPIED IN WHOLE OR IN PART AND (C) NOT BE USED OR INCORPORATED IN ANY PRODUCT, EXCEPT UNDER AN EXPRESS WRITTEN AGREEMENT WITH BECKMAN INSTRUMENTS, INC.

CHG.	E.O.NO.	DATE	BY	CHK
AA	---	---	---	---
AB	42133	3/26/04	CWB	SC
AC	42147	4/8/04	CWB	SC
AD	42297	9/1/04	BDC	SC
AE	42567	8/4/05	SC	AD

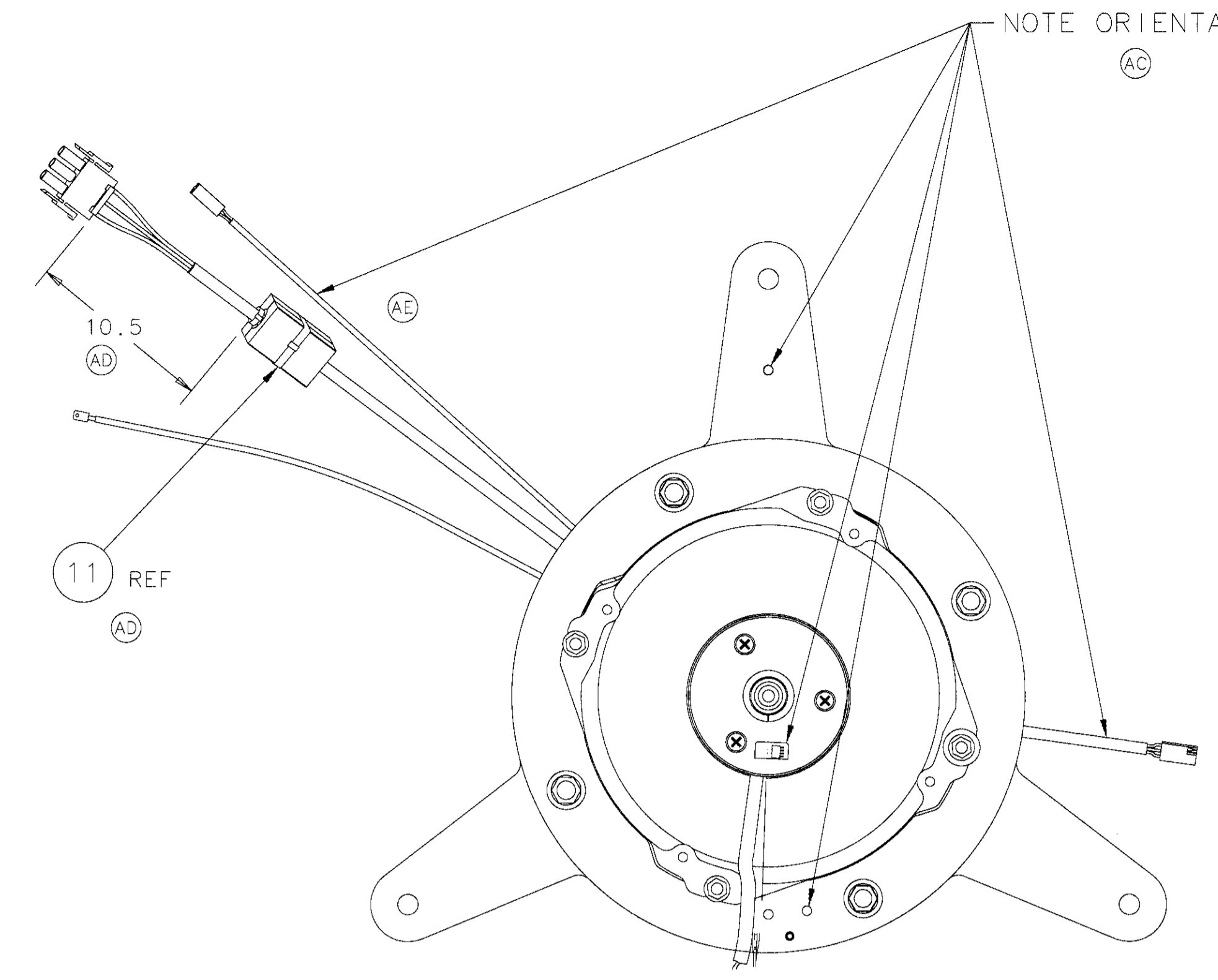
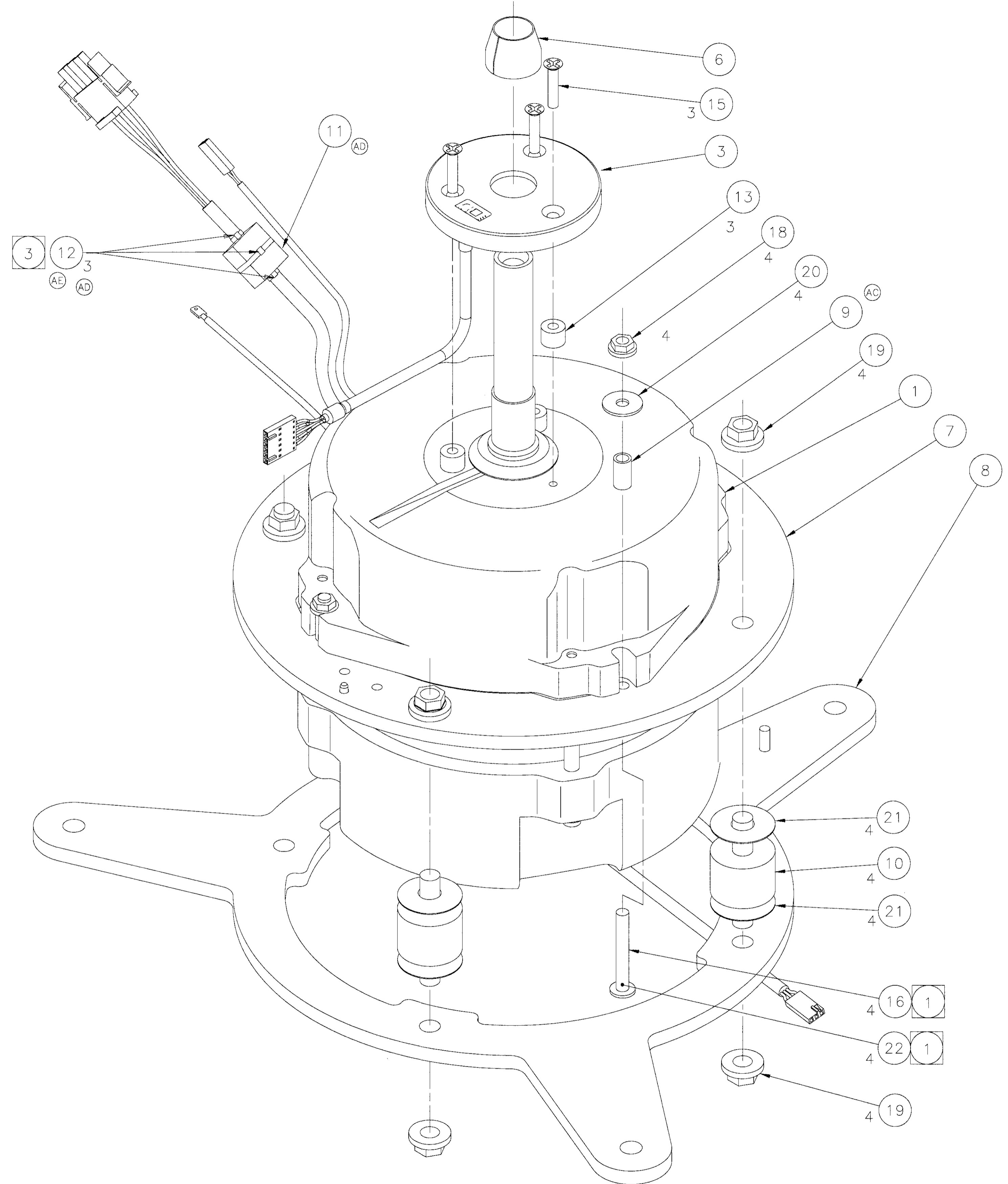

TOP VIEW

- ③ SECURE OUTSIDE OF FILTER (ITEM 11) WITH CABLE TIES (ITEM 12).
  - ② QUANTITIES IN PARENTHESIS "( )" ARE FOR REFERENCE ONLY. PARTS COME FROM JIT KIT 392949.
  - ① PRE-INSTALL SCREW (ITEM 16) TO RING MOUNT PLATE (ITEM 7). ADD ONE DROP LOCTITE (ITEM 22) TO SCREW (ITEM 16) ON AREA AS SHOWN.
- NOTES: (UNLESS OTHERWISE SPECIFIED)

22				
22	A/R	6000144	LOCTITE, 262	
21	8	961811	WASHER, SAND PAPER	
20	4	878492	WASHER, FLAT #10 .199 ID X.64 OD SS	
19	8	885321	NUT, SLFLKG. .312-18THD STL ZINC	
18	4	964847	NUT, SLFLKG M5 X0.5 ZINC	
17				
16	4	979224	SCREW, CAP M5 X 0.8 X 30MM BU SS HXSO	
15	3	979177	SCREW, M4X0.7 X 20mm LG, FLAT 90° SS	
14				
13	3	A17712	SPACER, .166 ID X .375 OD X.281 LG AL	
12	3	878485	CABLE TIE	
11	1	963700	BEAD, FILTER	
10	4	392997	SANDWICH MOUNT, COMPRESSION	
9	4	393000	SPACER, MOTOR TIE DOWN	
8	(1)	392921	PLATE, SUSPENSION, MOTOR	
7	(1)	392919	PLATE, RING MOUNT, MOTOR	
6	1	392361	FERRULE, DRIVE SHAFT	
5				
4				
3	1	392916	HOUSING ASSY, ROTOR ID	
2				
1	1	392914	MOTOR, HANNING	

UNLESS OTHERWISE SPECIFIED		ITEM	QTY	PART NO.	DESCRIPTION
MATERIAL	DIMENSIONS ARE IN INCHES TOLERANCES .X +.050 ANGLAR +0° 30' .XX +.020 .XXX +.005 MACH. SURF. ✓	DR	H. TRAN	02-12-04	BECKMAN
FINISH	INTERNAL THD HEIGHT 55* MIN THREADS: CLASS 2A OR 2B REMOVE BURRS & SHARP EDGES .020 MAX. MACH. FILLET RADIUS .020 MAX. MACH. SURF. FLAT WITHIN .001 IN./IN. OTHER SURF. FLAT WITHIN .005 IN./IN. CONCENTRICITY MACH. SURF. T.I.R. WITHIN 1/2 SUM OF DIAS. TOLS., .001 MIN. DO NOT SCALE DRAWING	CHK	C. W. BROWN	3/4/04	TITLE
		DSGN	H. TRAN	3/4/04	DRIVE ASSEMBLY
		ENGR	G. ERMOLI	3/4/04	D CODE IDENT NO. 07978
					DWG NO. 392923
					SCALE NONE 1st USE 392931 SHEET 1 OF 1

392923  
Dwg No

D1  
C 1737

CHG.	E.O.NO.	DATE	BY	CHK
AA				
AB	42118	03-21-04	HT	SC
AC	42657	11-18-05	SC	

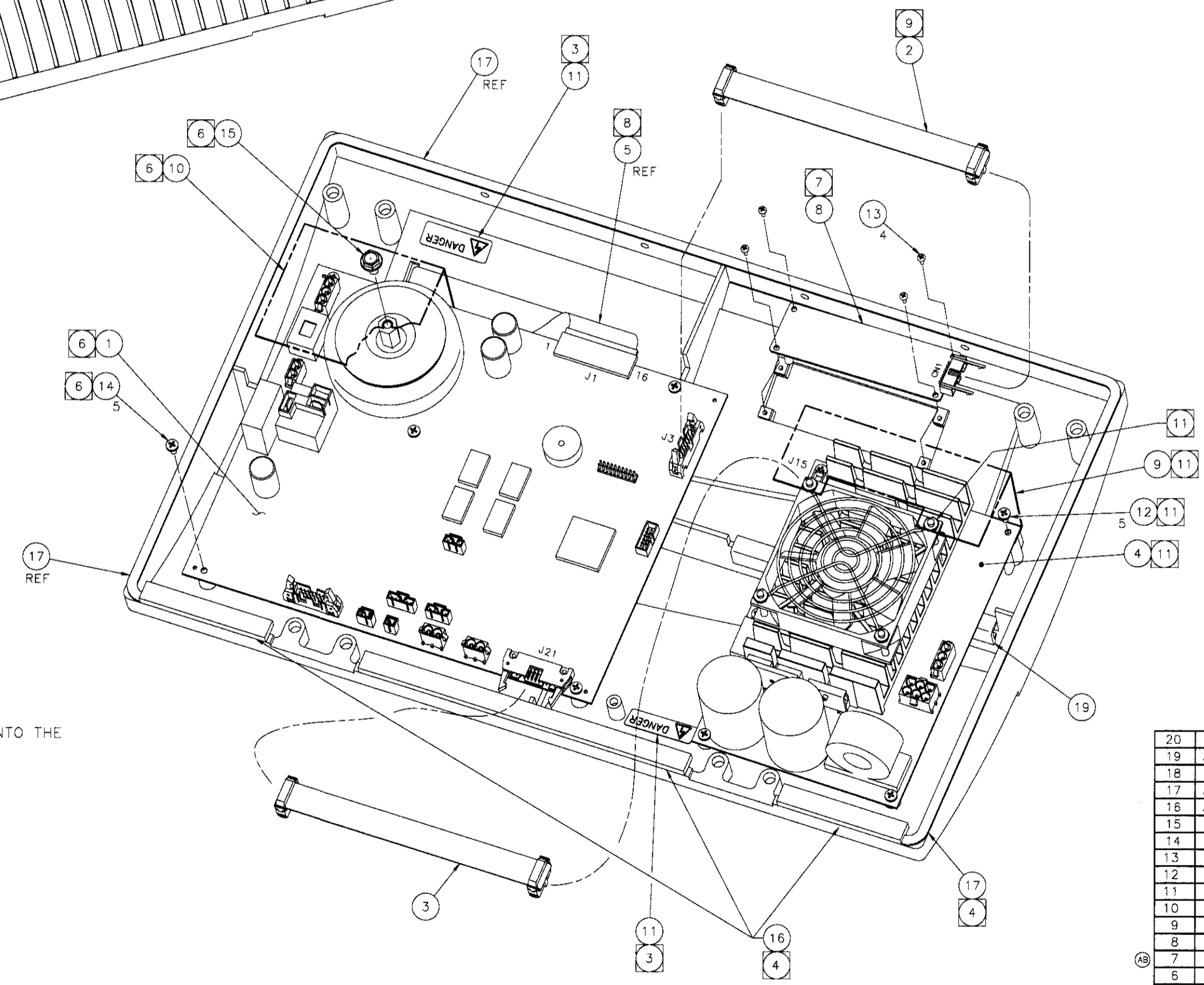
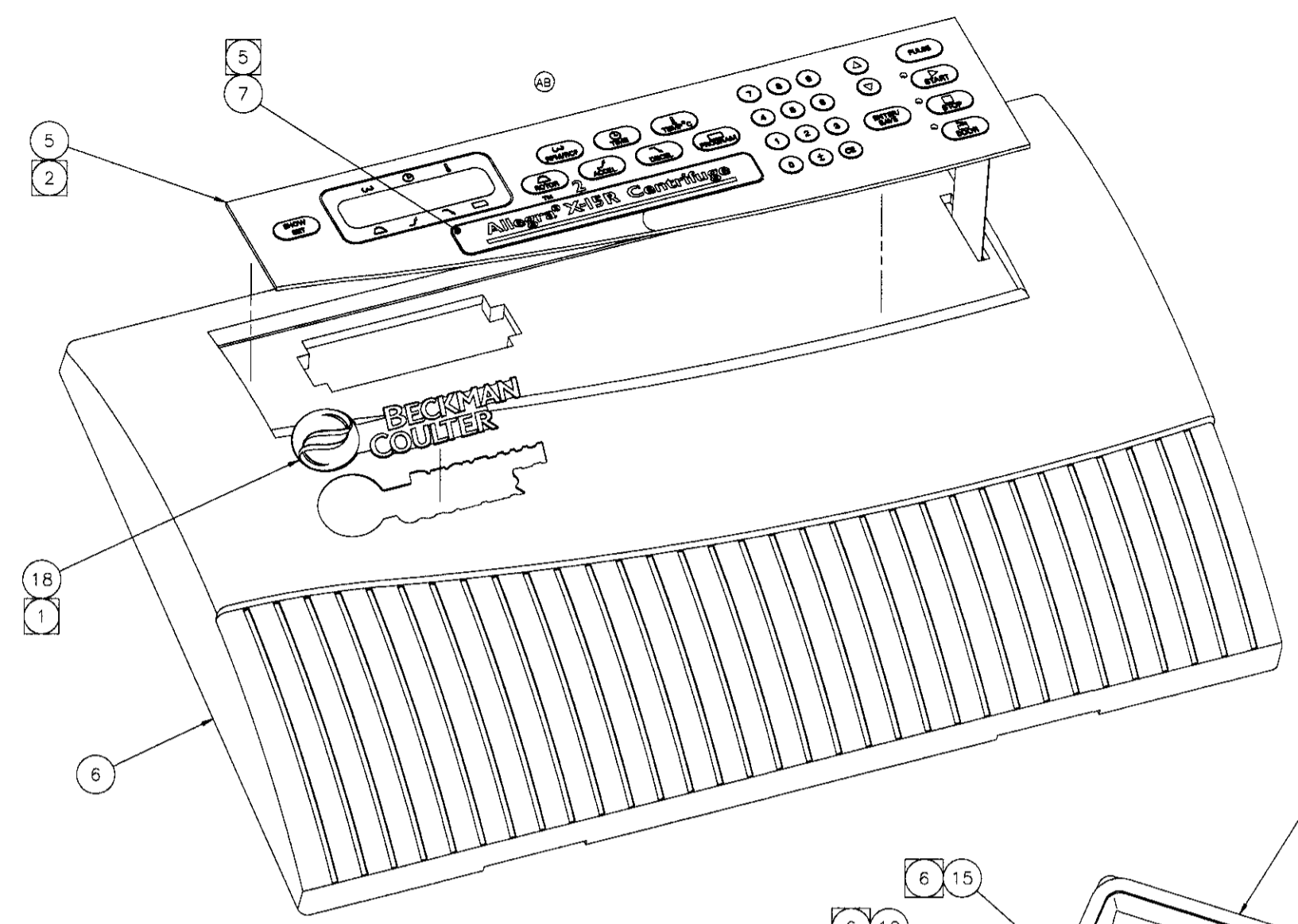

- 11 PLACE HOLE OPENINGS ON SHROUD (ITEM 9) UNDERNEATH DRIVER BOARD (ITEM 4) PRIOR TO MOUNTING BOARD TO FRONT PANEL (ITEM 6) WITH SCREWS (ITEM 12). REMOVE 2 NUTS (PART OF ITEM 4) THEN SECURE SHROUD TO TOP OF FAN GUARD (PART OF ITEM 4) BY RE-INSTALLING 2 NUTS.
- 10 QUANTITY IN PARENTHESIS \*( ) \* FOR REFERENCE ONLY. PART COMES FROM JIT KIT 392995 (HARNESS).
- 9 CONNECT TAIL OF CABLE (ITEM 2) TO APPROPRIATE CONNECTOR (J3) OF BOARD ASSY (ITEM 1) AND OTHER TAIL TO CONNECTOR (CN1) OF VFD DISPLAY ASSEMBLY (ITEM 8).
- 8 CONNECT TAIL OF MEMBRANE (ITEM 5) TO APPROPRIATE CONNECTOR (J1) OF BOARD ASSY (ITEM 1).
- 7 INSERT VFD DISPLAY ASSEMBLY (ITEM 8) WITH GLASS FACING THE FRONT INTO THE SQUARE OPENING ON THE LEFT SIDE OF PANEL (ITEM 6). USE SCREW (ITEM 13) TO FASTEN IN PLACE.
- 6 PLACE HOLE OPENING ON SHROUD (ITEM 10) UNDERNEATH CONTROL BOARD (ITEM 1) PRIOR TO MOUNTING BOARD TO FRONT PANEL (ITEM 6) WITH SCREWS (ITEM 14). THEN SECURE SHROUD TO STANDOFF ON TOP OF TRANSFORMER (PART OF ITEM 1) WITH SCREW (ITEM 15).
- 5 REMOVE PROTECTIVE COVERING FROM BACK OF NAME PLATE (ITEM 7), AND PLACE ON MEMBRANE (ITEM 5) AS SHOWN.
- 4 REMOVE PROTECTIVE COVERING FROM BACK OF EMI SHIELD (ITEM 16 & 17), AND PLACE ALONG OUTSIDE EDGE OF PANEL (ITEM 6) AS REQUIRED.
- 3 ORIENT LABELS (ITEM 11) AS SHOWN.
- 2 REMOVE PROTECTIVE COVERING FROM BACK OF MEMBRANE (ITEM 5), SLIDE CONNECTOR THROUGH SLIT ON RIGHT SIDE OF PANEL (ITEM 6), AND PLACE MEMBRANE IN LARGE RECESSED AREA OF PANEL.
- 1 REMOVE PROTECTIVE COVERING FROM BACK OF LOGO (ITEM 18), AND PLACE IN RECESSED POCKET OF PANEL (ITEM 6).

NOTES: (UNLESS OTHERWISE SPECIFIED).

20			
19	A/R	4522947	EXTRUSION, PVC, BLACK
18	1	605187	LOGO, 5 INCH
17	A/R	A11264	SHIELD, EMI - .25 WD X .140 THK
16	A/R	4201301	SHIELD, EMI - .5 WD X .25 THK
15	1	964855	SCREW, M6 X 1.0 X 12mm HXFLG
14	5	A10909	SCREW, M3.5 X 0.6 X 8mm P-S-ZI-PHIL
13	4	979556	SCREW, M2 X 0.4 X 6mm P-S-ZI-PHIL
12	5	970582	SCREW, M3.0 X 0.5 X 8mm P-S-ZI-PHIL
11	2	456025	LABEL, HIGH VOLTAGE
10	1	392728	SHROUD, CONTROL BOARD
9	1	392727	SHROUD, DRIVER BOARD
8	1	392741	VFD DISPLAY ASSEMBLY
7	1	392920	NAME PLATE, ALLEGRA X-15R
6	1	392378	PANEL, FRONT
5	1	392377	CONTROL PANEL MEMBRANE
4	1	393289	DRIVER BOARD ASSY
3	(1)	392460	CABLE, DRIVER INTERFACE
2	(1)	392459	CABLE, VFD
1	1	392963	BOARD ASSY, CONTROL DRIVER
ITEM QTY		PART NO.	
		DESCRIPTION	
BY		DATE	
DR H. TRAN		02-18-04	
CHK CRISS BROWN		03-09-04	
DSGN H. TRAN		03-09-04	
ENGR BRAD CARSTENS		03-09-04	
		BECKMAN INSTRUMENTS INC.	
		10000 WILSON BLVD. IRVING, TX 75039-2100	
		TITLE	
		CONTROL PANEL ASSEMBLY	
		E CODE IDENT NO. DWG NO.	
		07978 392939	
		SCALE NONE 1st USE 392931 SHEET 1 OF 1	

THIS DOCUMENT CONTAINS PROPRIETARY INFORMATION OF BECKMAN COULTER, INC. AND IS INTENDED SUBJECT TO THE CONDITIONS THAT THE INFORMATION (A) BE RETAINED IN CONFIDENCE, (B) NOT BE REPRODUCED OR COPIED IN WHOLE OR IN PART AND (C) NOT BE USED OR INCORPORATED IN ANY PRODUCT, EXCEPT UNDER AN EXPRESS WRITTEN AGREEMENT WITH BECKMAN COULTER, INC.

REV	E.O. NO.	DATE	BY	CHK
AA				
AB	42143	04-05-04	HT	SC
AC	42227	06-29-04	HT	SC
AD	42267	9-9-04	SC	CWB
AE	42484	7/6/05	CWB	AE

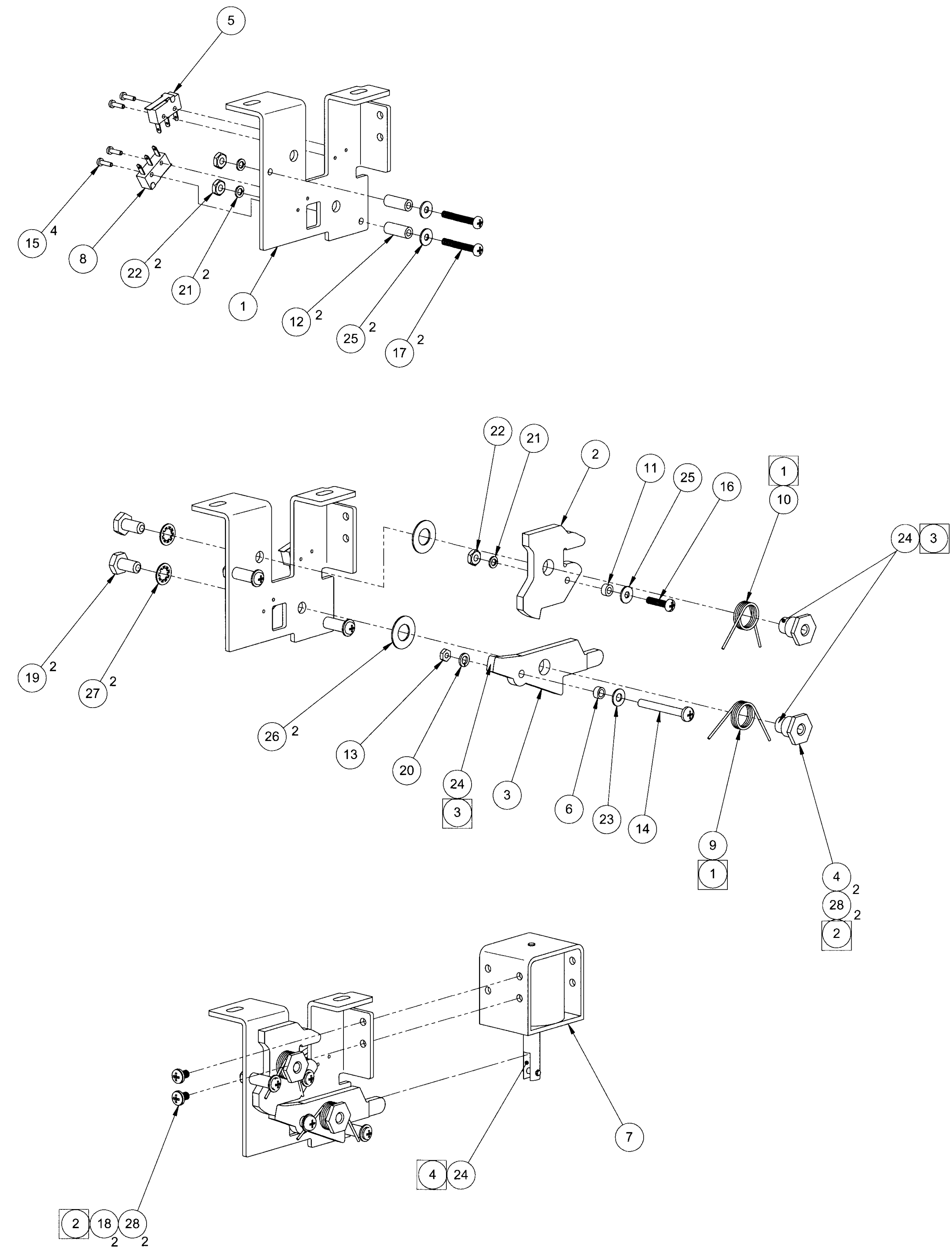

- ④ APPLY LUBRICANT ( ITEM 24 ) TO ALL INTERIOR SURFACES OF PLUNGER ( PART OF ITEM 7 ) PRIOR TO ASSEMBLY.
- ③ APPLY LUBRICANT ( ITEM 24 ) TO INDICATED SURFACES OF LOCK ( ITEM 3 ) AND MANDREL ( ITEM 4 ) PRIOR TO ASSEMBLY.
- ② APPLY LOCTITE ( ITEM 28 ) TO SCREW ( ITEM 18 ) AND THREADS OF MANDREL ( ITEM 4 ) PRIOR TO ASSEMBLY. ALL EXTERNAL SURFACES OF MANDREL TO BE FREE OF LOCTITE.
- ① TRIM SPRING LEGS ( ITEMS 9 AND 10 ) TO 1.050 ± .020 IN FROM TANGENT PRIOR TO ASSEMBLY.

NOTE: ( UNLESS OTHERWISE SPECIFIED )

ITEM	QTY.	PART NO.	DESCRIPTION
28	A/R	6000144	LOCTITE THREADLOCKER - 262
27	2	811944	WSHR, INTLTK, .267X.478 ST
26	2	A13525	WSHR, FTL-TFL, .372 X.735
25	3	976498	WSHR, FLT.141X.375X.032
24	A/R	6500402	LUBRICANT, WHITE - LUBRIPLATE 105
23	1	964260	WSHR, FLT .179 X.385 X.03
22	3	808596	NUT, HEX 6-32 STL ZN
21	3	808266	WSHR, SPLIT 6-32 STL ZINC
20	1	808268	WSHR-SPLIT #8 .04 THK, ST
19	2	A13524	SCR. MACH 8X.25-P-S-ZN-PHIL
18	2	804435	SCR, MACH 8X.25-P-S-ZN-PHIL
17	2	804418	SCR, MACH 6X1-P-S-ZN-PHIL
16	1	804405	SCREW, MACH 6 X .625-PNH STL ZN PL PHH
15	4	804324	SCR. 2-56X.312 PNH-PHH ST
14	1	885615	SCR, 8-32 X 1.375 PNH, SS
13	1	847771	NUT, HEX 8-32 STL ZINC
12	2	827507	SPCR, .14 X .25 X .625 S
11	1	A13851	SPCR, .14IDX .25ODX .125
10	1	A13383	SPR, TORS, LH .618ID .048
9	1	A13384	SPR, TORS, RH, .618 X.048
8	1	A13385	SW, SENS.,-SPDT, 6A 120V
7	1	392996	SOLENOID ASSEMBLY
6	1	A23914	SPCR, .166X.25X.125 S-ZI
5	1	A15801	SW, SENS.-SPDT 6A 250V
4	2	392896	MANDREL, LATCH-SHORT
3	1	392897	LOCK, DOOR LATCH
2	1	392899	LATCH, DOOR
1	1	392898	BRACKET, DOOR LATCH

BY		DATE	<b>BECKMAN COULTER</b> <small>1050 Page Mill Road Falo Alto, CA 94304</small>
DR	C. W. BROWN	12/11/03	
CHK	C. STEWART	3/3/04	
ENGR	A. ANGELES	3/3/04	
TITLE			<b>LATCH ASSEMBLY, DOOR</b>
SIZE DWG. NO. REV <b>D 392900 AE</b>			
MOD ALLEGRA X-15R   NEXT ASSY 392931   SCALE N/A   CAD FILE: 392900.slddrw   SHEET 1 OF 1			

THIS DOCUMENT CONTAINS PROPRIETARY INFORMATION OF BECKMAN INSTRUMENTS, INC. AND IS TENDERED SUBJECT TO THE CONDITIONS THAT THE INFORMATION (A) BE RETAINED IN CONFIDENCE, (B) NOT BE REPRODUCED OR COPIED IN WHOLE OR IN PART AND (C) NOT BE USED OR INCORPORATED IN ANY PRODUCT, EXCEPT UNDER AN EXPRESS WRITTEN AGREEMENT WITH BECKMAN INSTRUMENTS, INC.

REV.	E.O.NO.	DATE	BY	CHK
AA				
AB	42121	3/24/04	JW	
AC	42153	4/13/04	JW	CWB
AD	42173	5/17/04	JW	CWB
AE	42193	6/8/04	JW	CWB

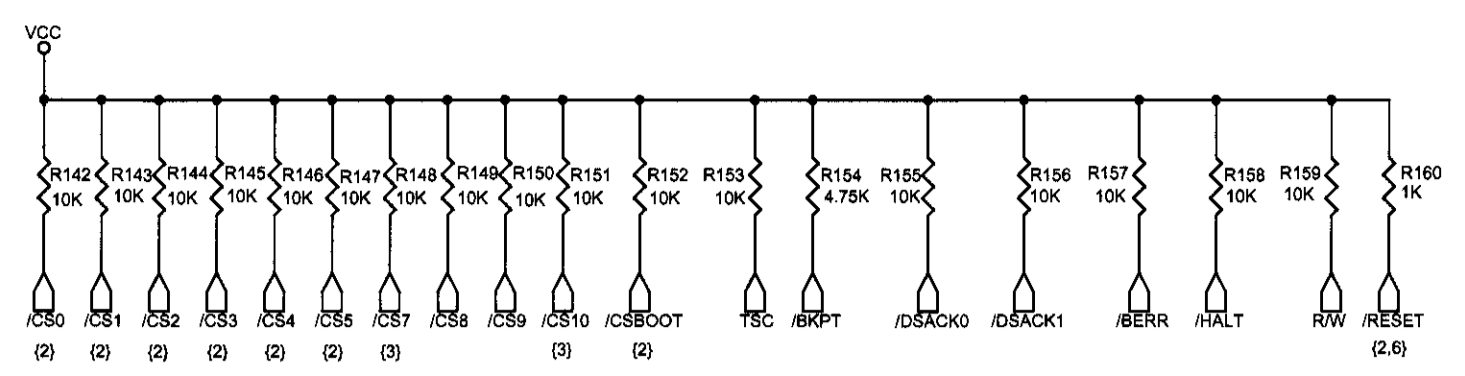

RESET MODE LINES

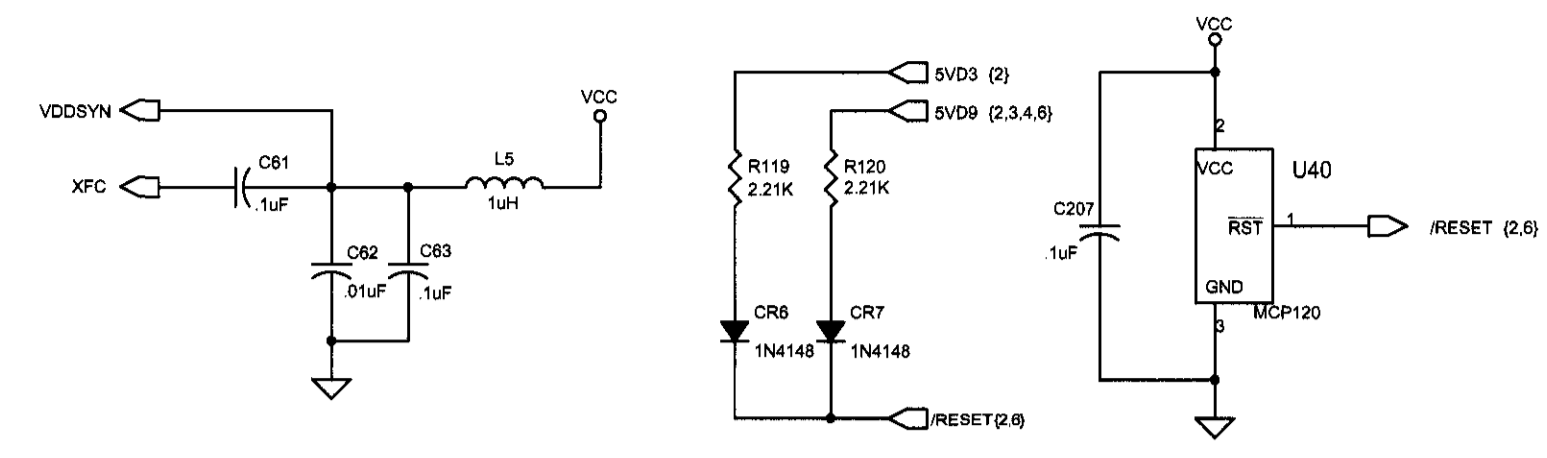

SERIAL EXPANSION PORT

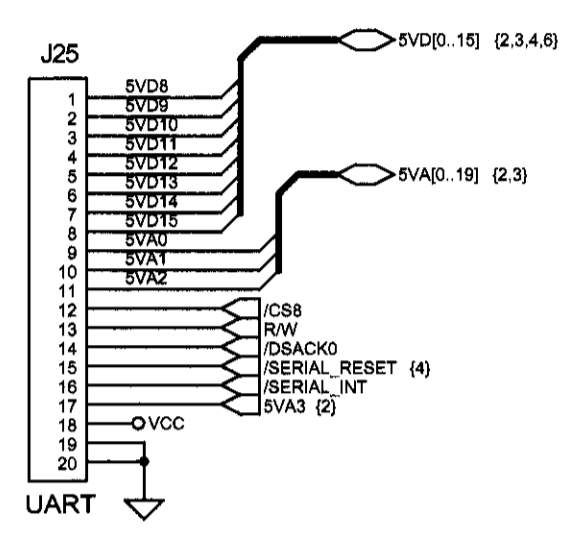

BDM PORT

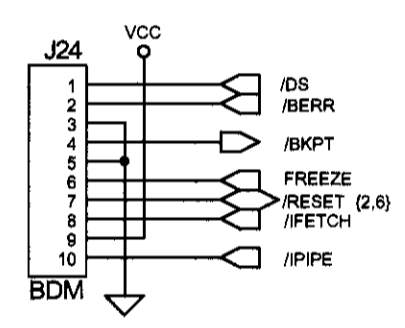

DRIVER BOARD INTERFACE

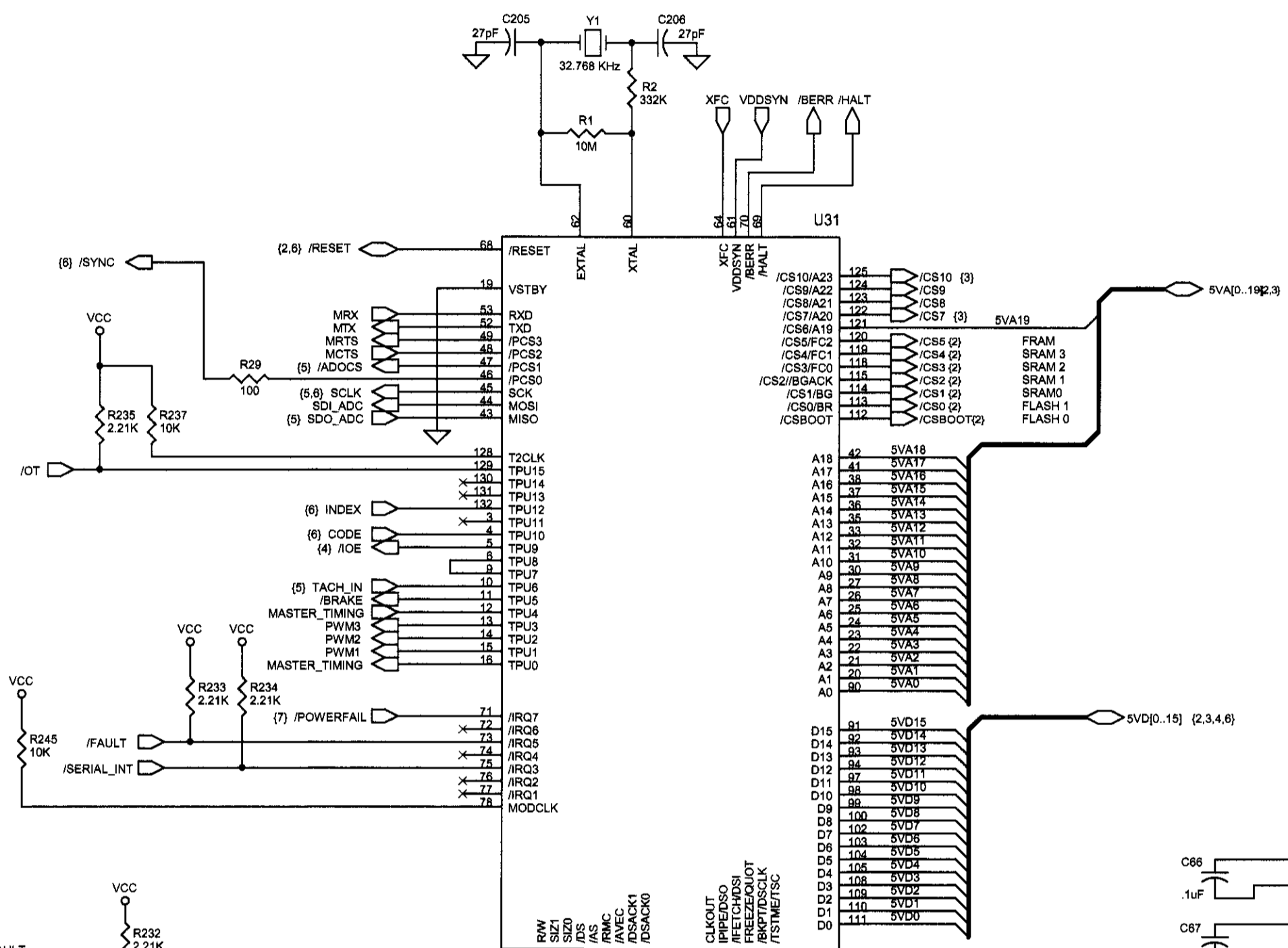
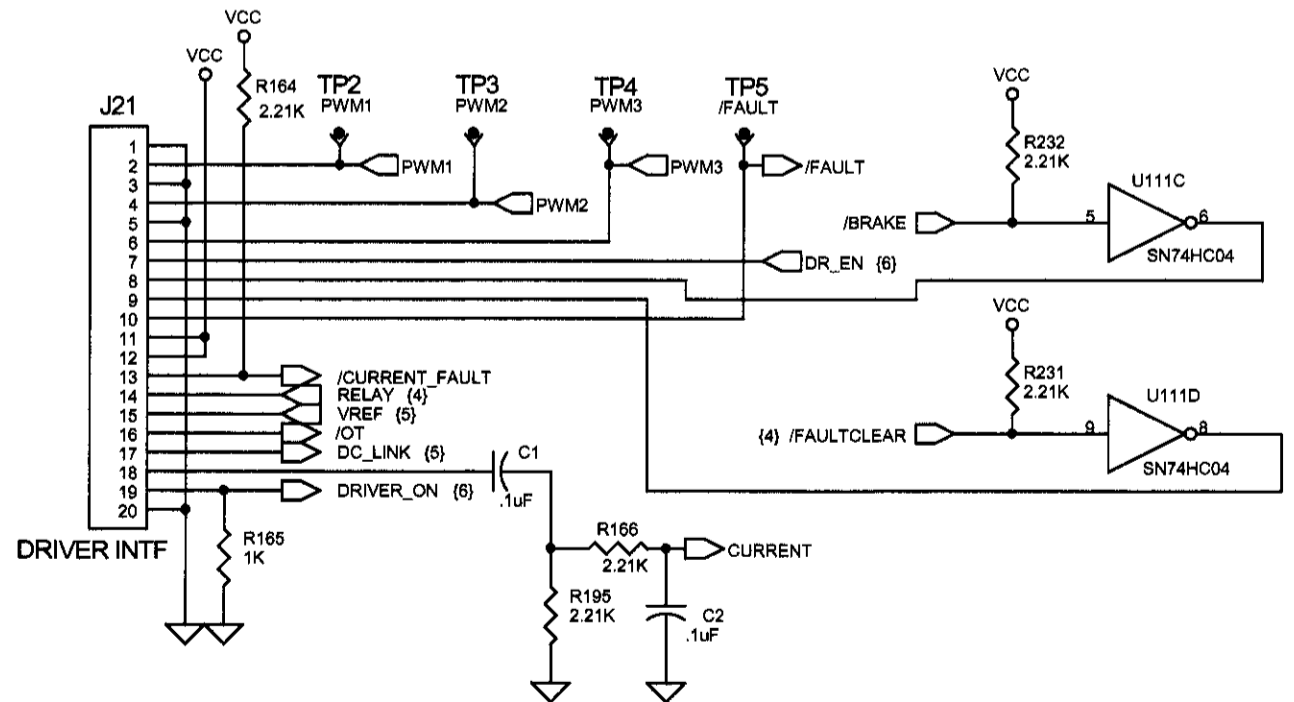

SCI PORT

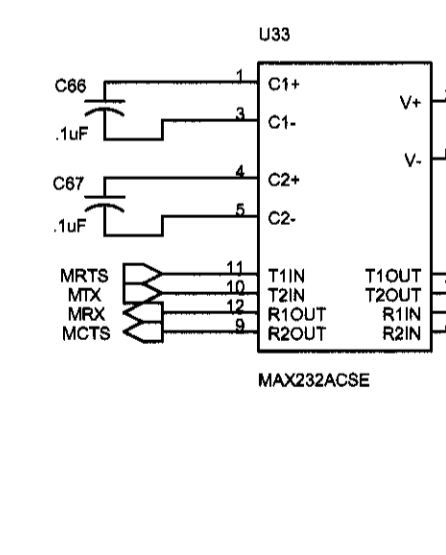

SERIAL INTERFACE

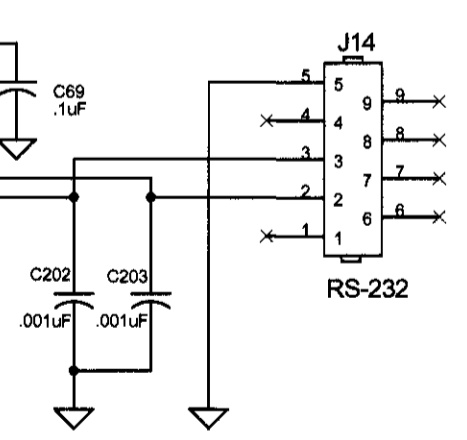

- 5. ⚡ DENOTES NOISY (EARTH DIGITAL) GROUND.
  - 4. CAPACITOR VALUES ARE IN MICROFARADS.
  - 3. RESISTOR VALUES ARE IN OHMS.
  - 2. BOARD ASSEMBLY IS 392963.
  - 1. REF OVERALL SCHEMATIC 392961-00.
- NOTES: (UNLESS OTHERWISE SPECIFIED)

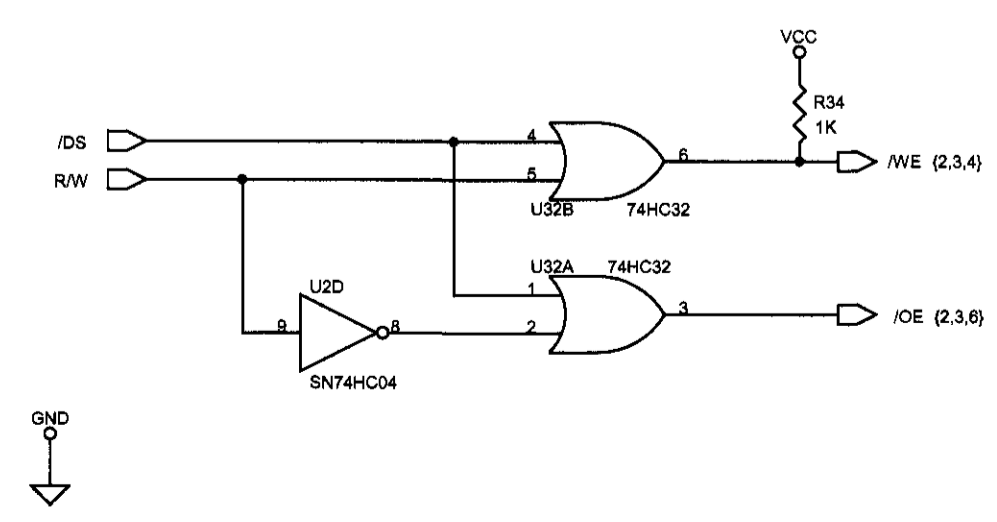

BY	DATE	BECKMAN	
DR J.MURPHY	2/04	BECKMAN INSTRUMENTS, INC. SPINCO DIVISION 1050 PAGE MILL ROAD PALO ALTO, CA 94304	
CHK J.WILLIAMS	3/12/04	TITLE	SCHEMATIC - CONTROL DRIVER
DSGN			
ENGR J.MURPHY	3/12/04		
		CODE IDENT NO.	DWG NO.
		07978	392961-01
MOD ALLEGRA X-15R	SCALE	1st USE	SHT 1 OF 7

392961-01



THIS DOCUMENT CONTAINS PROPRIETARY INFORMATION OF BECKMAN INSTRUMENTS, INC. AND IS TENDERED SUBJECT TO THE CONDITIONS THAT THE INFORMATION (A) BE RETAINED IN CONFIDENCE (B) NOT BE REPRODUCED OR COPIED IN WHOLE OR IN PART AND (C) NOT BE USED OR INCORPORATED IN ANY PRODUCT, EXCEPT UNDER AN EXPRESS WRITTEN AGREEMENT WITH BECKMAN INSTRUMENTS, INC.

REV.	E.O.NO.	DATE	BY	CHK
AE		SEE SHT 1		

LEVEL SHIFTERS

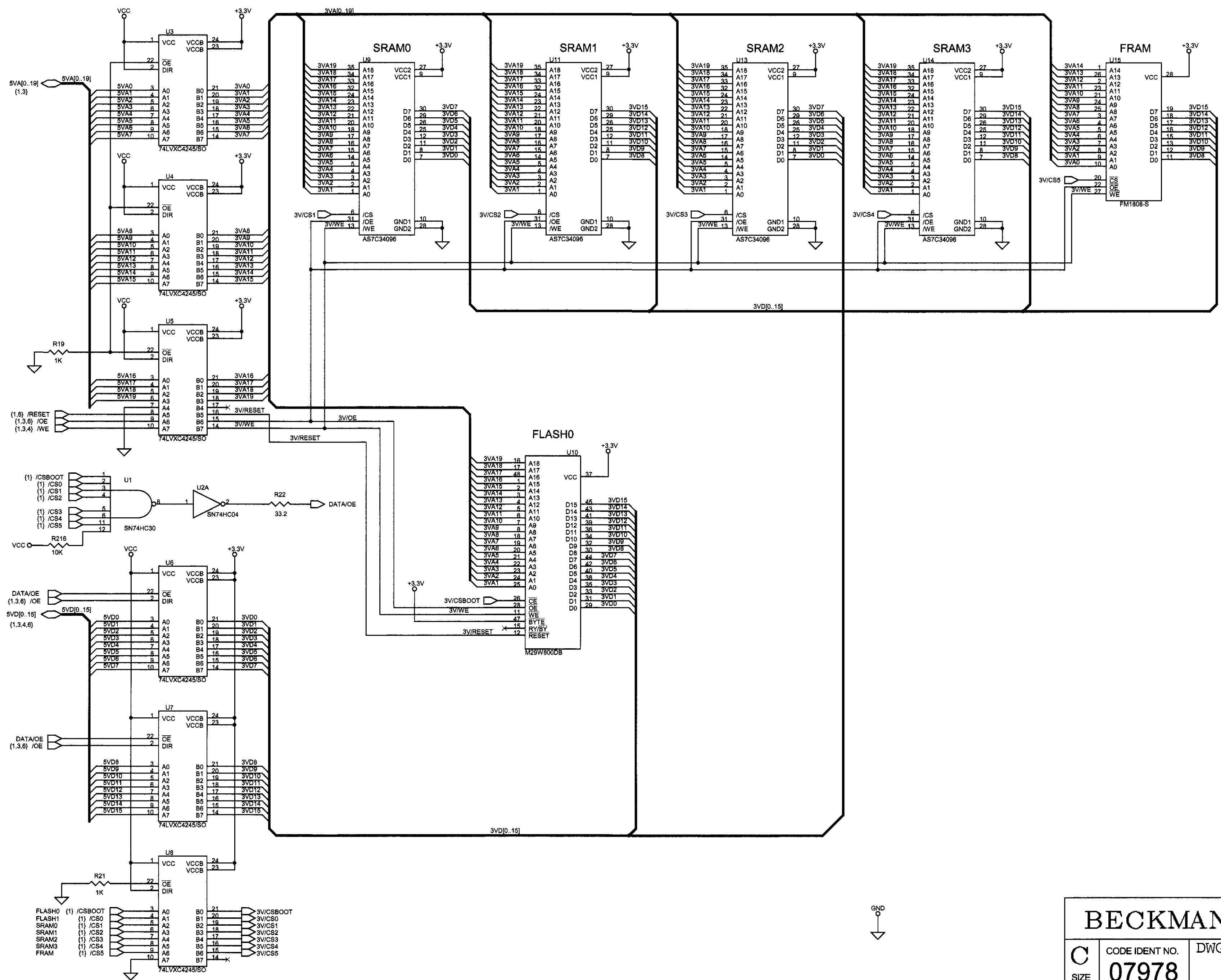

392961-01

<b>BECKMAN</b>		BECKMAN INSTRUMENTS, INC. SPINCO DIVISION 1050 PAGE MILL ROAD PALO ALTO, CA 94304	
<b>C</b> SIZE	CODE IDENT NO.	DWG NO.	
	07978	392961-01	
SCALE	1st USE	SHT 2 OF 7	

THIS DOCUMENT CONTAINS PROPRIETARY INFORMATION OF BECKMAN INSTRUMENTS, INC. AND IS TENDERED SUBJECT TO THE CONDITIONS THAT THE INFORMATION (A) BE RETAINED IN CONFIDENCE, (B) NOT BE REPRODUCED OR COPIED IN WHOLE OR IN PART AND (C) NOT BE USED OR INCORPORATED IN ANY PRODUCT, EXCEPT UNDER AN EXPRESS WRITTEN AGREEMENT WITH BECKMAN INSTRUMENTS, INC.

REV.	E.O.NO.	DATE	BY	CHK
AE	SEE SHT 1			

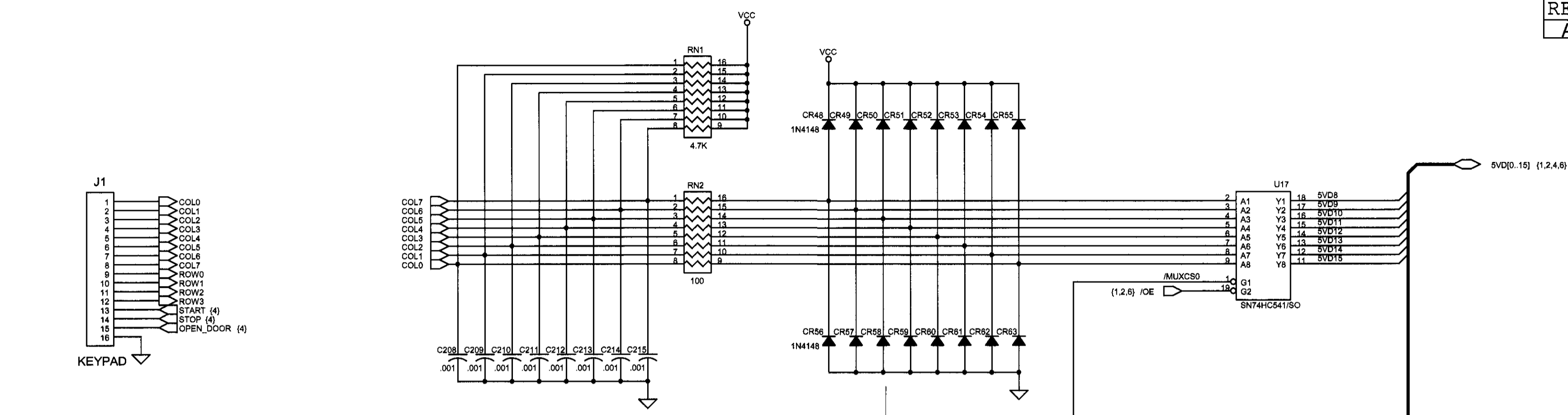

		COLUMN							
ROW		0	1	2	3	4	5	6	7
0					0	+/-	CE		
1		ROTOR	SHOW	DOOR	1	2	3	ENTER	STOP
2		ACCEL	DECEL	PROG	4	5	6	DWN	START
3		RPM	TIME	TEMP	7	8	9	UP	PULSE

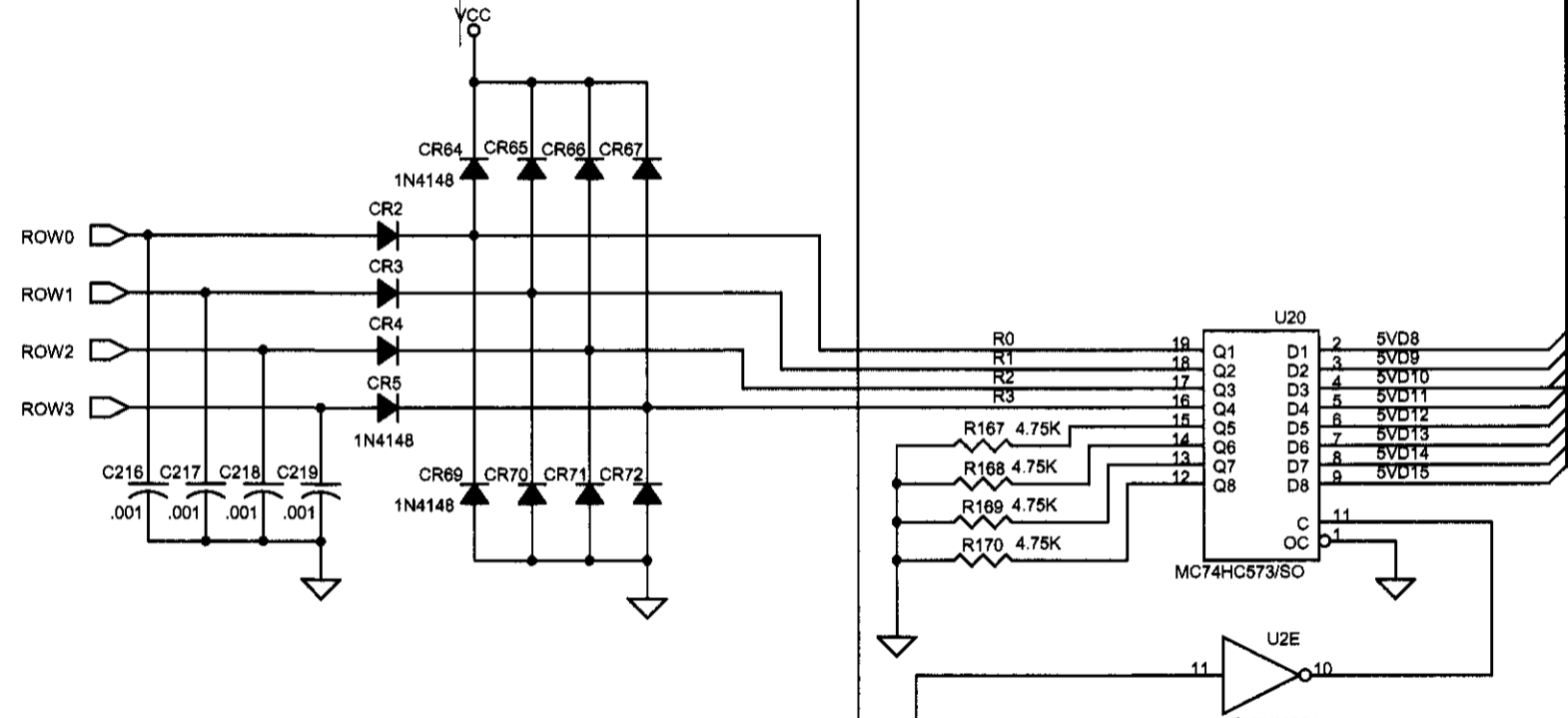

BI-DIRECTIONAL BUFFERS FOR VFD INTERFACE

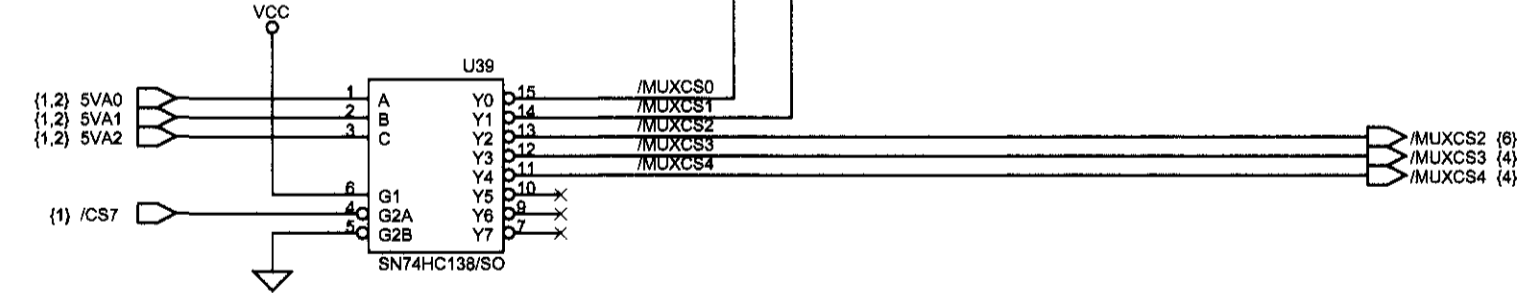
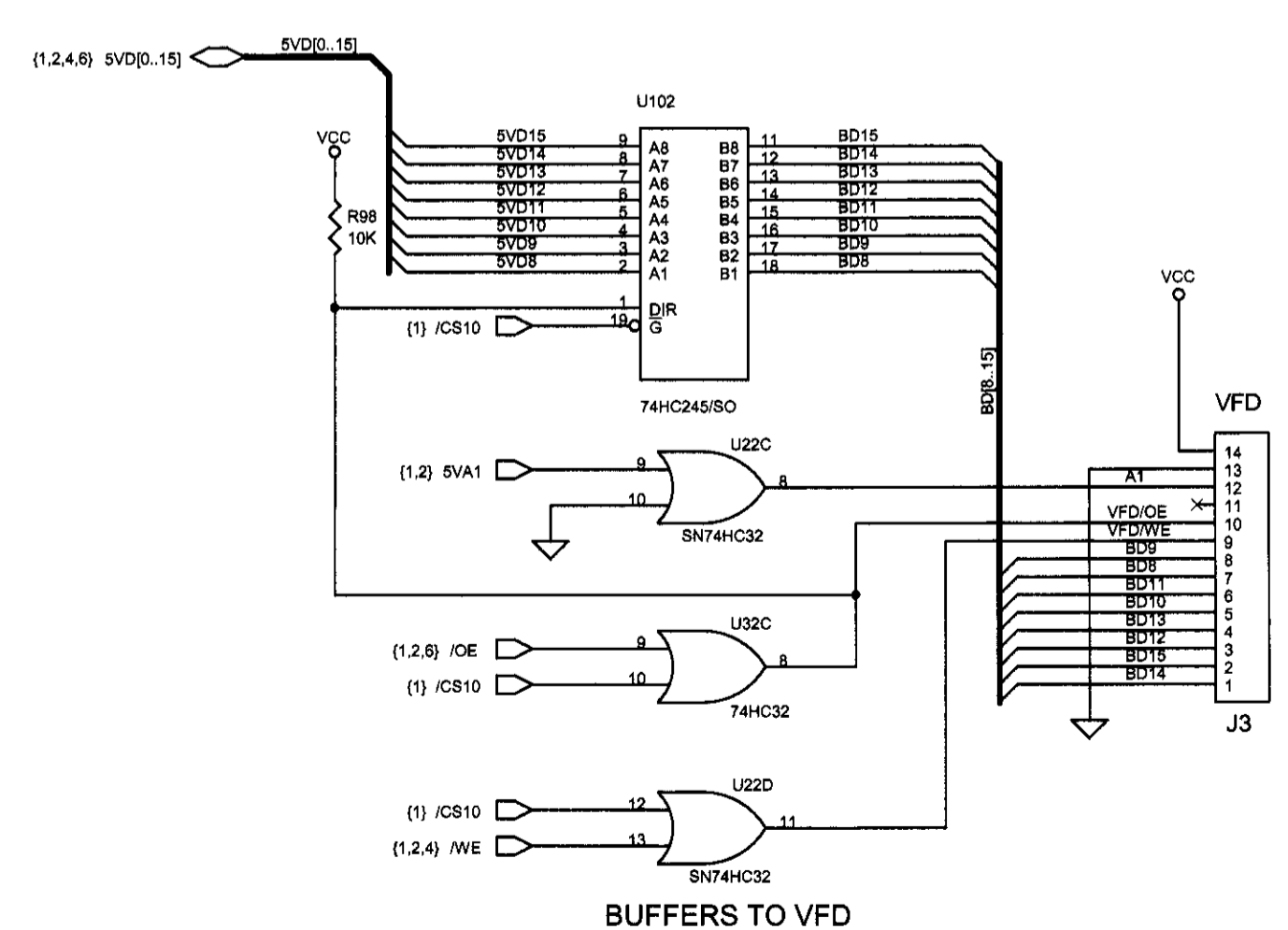

<b>BECKMAN</b>		BECKMAN INSTRUMENTS, INC. SPINCO DIVISION 1050 PAGE MILL ROAD PALO ALTO, CA 94304	
C SIZE	CODE IDENT NO. <b>07978</b>	DWG NO. <b>392961-01</b>	
SCALE	1st USE	SHT 3 OF 7	

392961-01

THIS DOCUMENT CONTAINS PROPRIETARY INFORMATION OF BECKMAN INSTRUMENTS, INC. AND IS TENDERED SUBJECT TO THE CONDITIONS THAT THE INFORMATION (A) BE RETAINED IN CONFIDENCE, (B) NOT BE REPRODUCED OR COPIED IN WHOLE OR IN PART AND (C) NOT BE USED OR INCORPORATED IN ANY PRODUCT, EXCEPT UNDER AN EXPRESS WRITTEN AGREEMENT WITH BECKMAN INSTRUMENTS, INC.

REV.	E.O.NO.	DATE	BY	CHK
AE		SEE SHT 1		

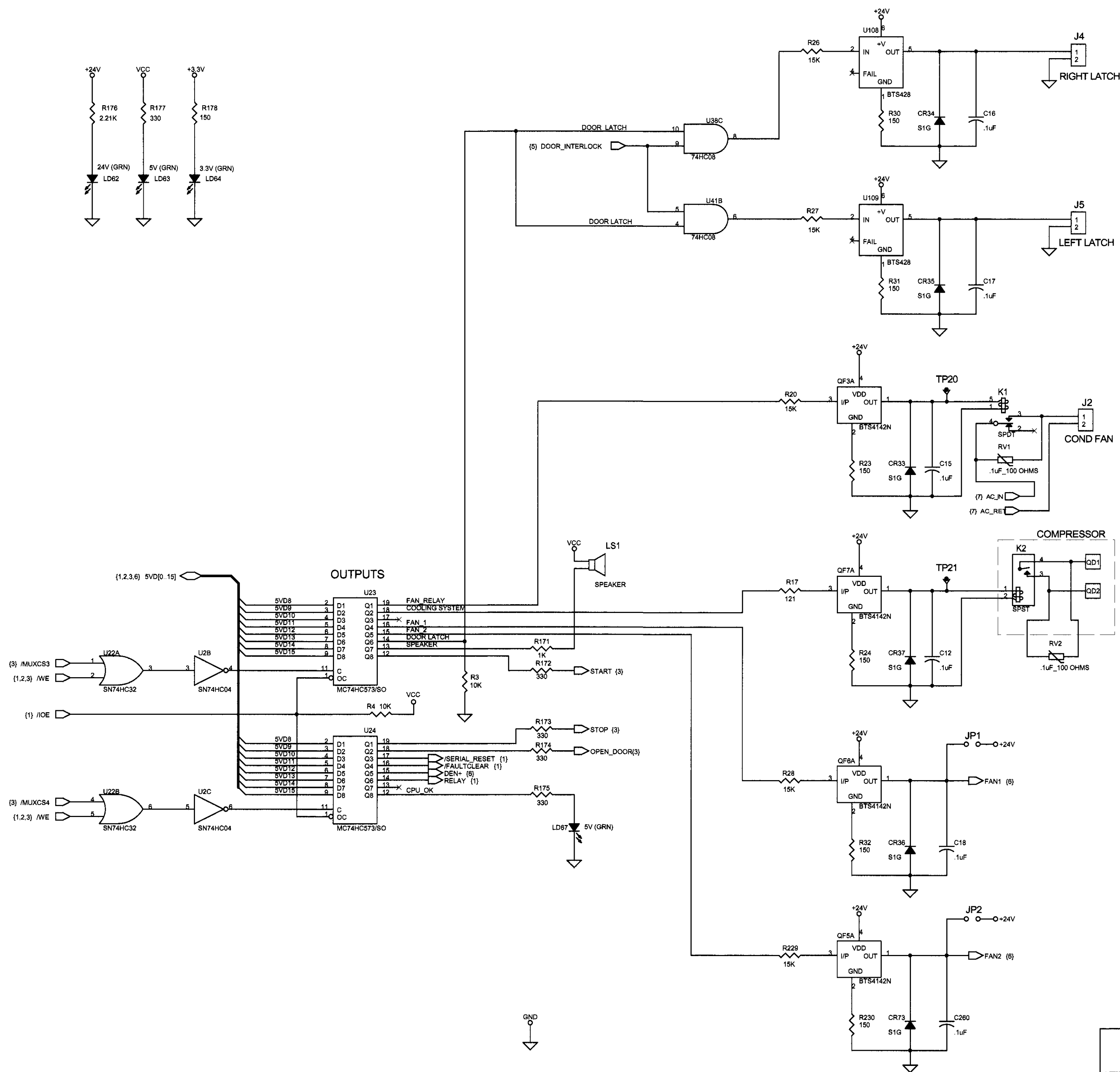

<b>BECKMAN</b>		BECKMAN INSTRUMENTS, INC. SPINCO DIVISION 1050 PAGE MILL ROAD PALO ALTO, CA 94304	
<b>C</b> SIZE	CODE IDENT NO. <b>07978</b>	DWG NO. <b>392961-01</b>	
	SCALE	1st USE	SHT 4 OF 7

C 392961-01



THIS DOCUMENT CONTAINS PROPRIETARY INFORMATION OF BECKMAN INSTRUMENTS, INC. AND IS TENDERED SUBJECT TO THE CONDITIONS THAT THE INFORMATION (A) BE RETAINED IN CONFIDENCE, (B) NOT BE REPRODUCED OR COPIED IN WHOLE OR IN PART AND (C) NOT BE USED OR INCORPORATED IN ANY PRODUCT, EXCEPT UNDER AN EXPRESS WRITTEN AGREEMENT WITH BECKMAN INSTRUMENTS, INC.

REV.	E.O.NO.	DATE	BY	CHK
AE		SEE SHT 1		

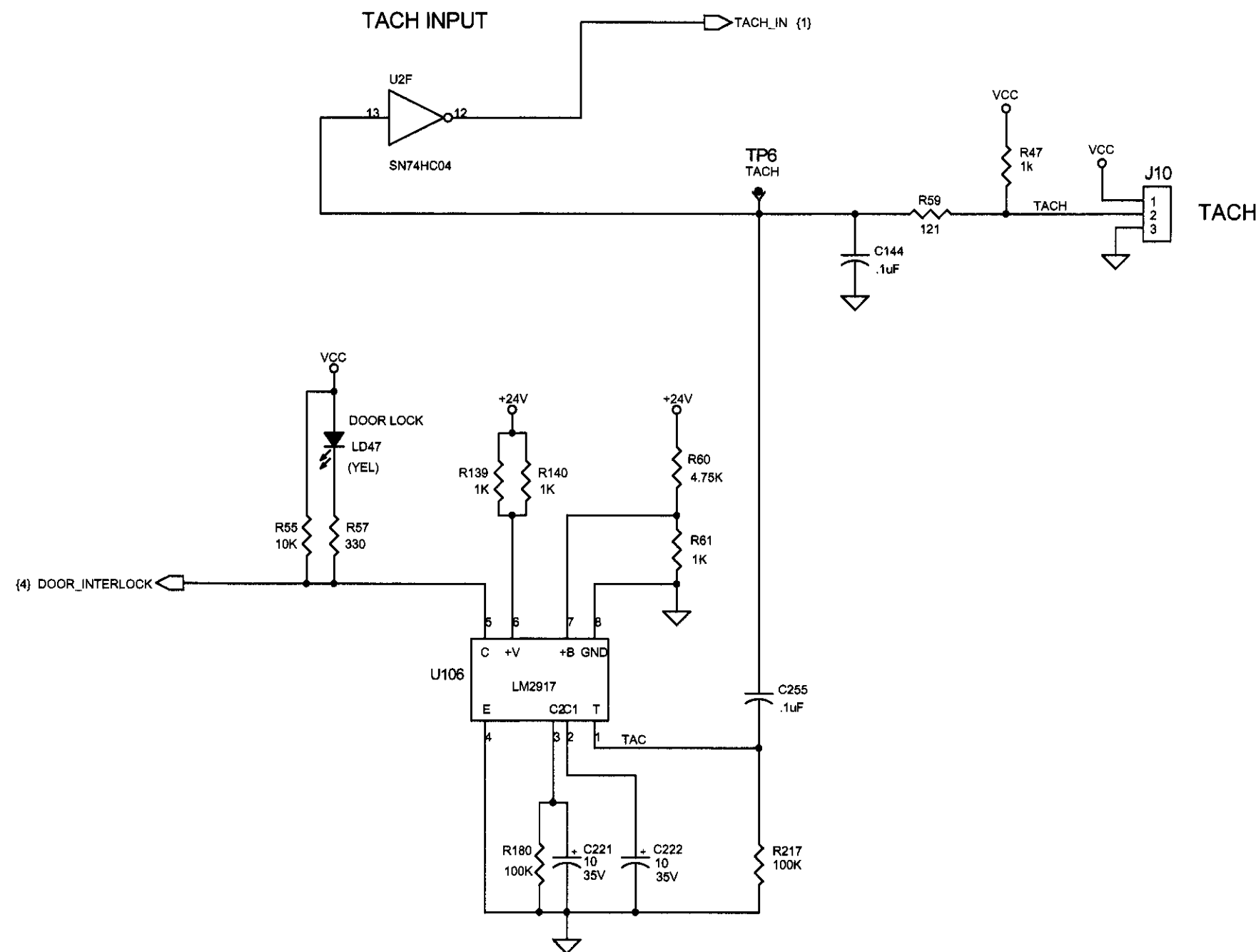
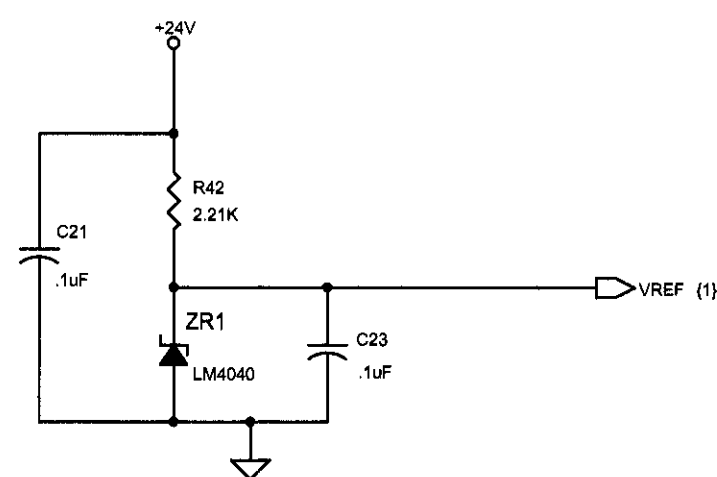
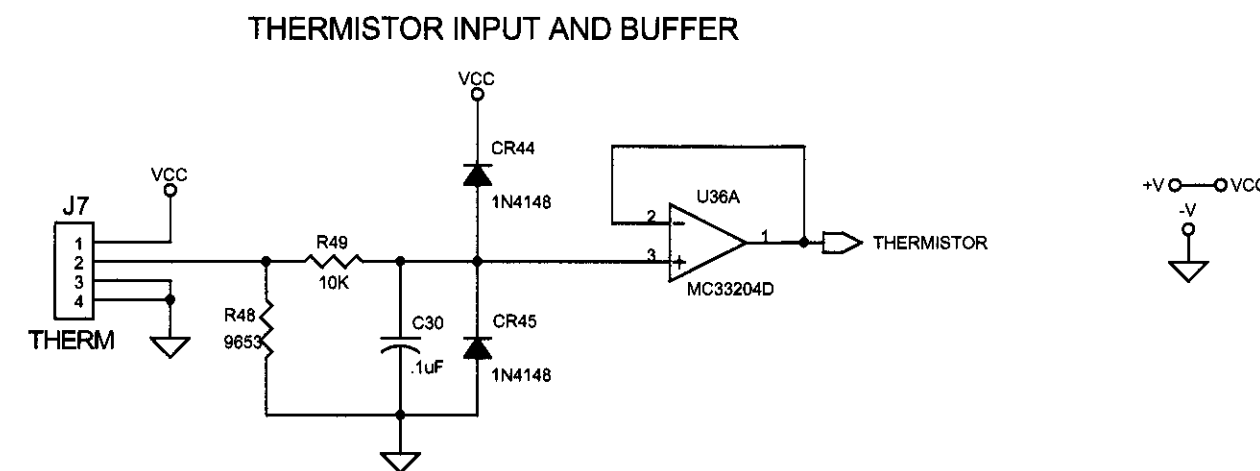
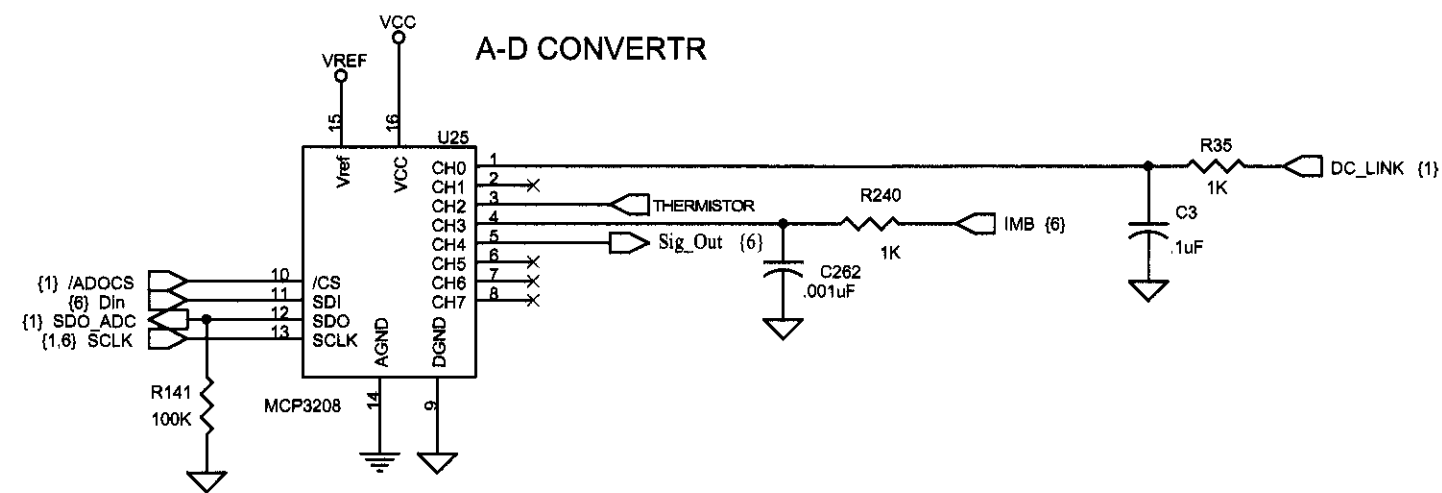

<b>BECKMAN</b>		BECKMAN INSTRUMENTS, INC. SPINCO DIVISION 1050 PAGE MILL ROAD PALO ALTO, CA 94304	
C SIZE	CODE IDENT NO. <b>07978</b>	DWG NO. <b>392961-01</b>	
SCALE	1st USE	SHT 5 OF 7	

C 392961-01

THIS DOCUMENT CONTAINS PROPRIETARY INFORMATION OF BECKMAN INSTRUMENTS, INC. AND IS TENDERED SUBJECT TO THE CONDITIONS THAT THE INFORMATION (A) BE RETAINED IN CONFIDENCE, (B) NOT BE REPRODUCED OR COPIED IN WHOLE OR IN PART AND (C) NOT BE USED OR INCORPORATED IN ANY PRODUCT, EXCEPT UNDER AN EXPRESS WRITTEN AGREEMENT WITH BECKMAN INSTRUMENTS, INC.

REV.	E.O.NO.	DATE	BY	CHK
AE	SEE SHT 1			

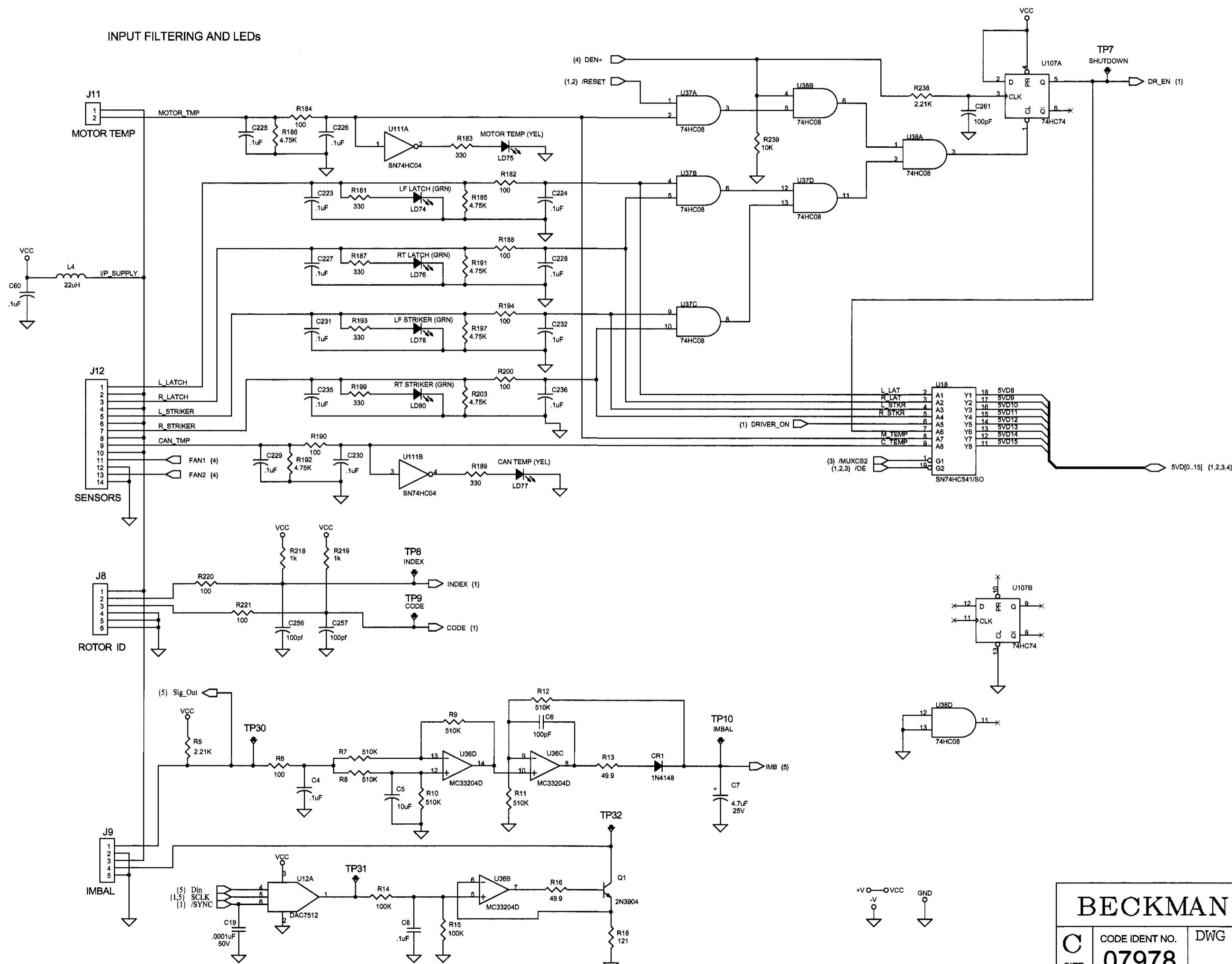

<b>BECKMAN</b>		BECKMAN INSTRUMENTS, INC. SPINCO DIVISION 1050 PAGE MILL ROAD PALO ALTO, CA 94304	
C SIZE	CODE IDENT NO. <b>07978</b>	DWG NO. <b>392961-01</b>	<b>392961-01</b>
SCALE	1st USE	SHT 6 OF 7	

C 392961-01

THIS DOCUMENT CONTAINS PROPRIETARY INFORMATION OF BECKMAN INSTRUMENTS, INC. AND IS TENDERED SUBJECT TO THE CONDITIONS THAT THE INFORMATION (A) BE RETAINED IN CONFIDENCE, (B) NOT BE REPRODUCED OR COPIED IN WHOLE OR IN PART AND (C) NOT BE USED OR INCORPORATED IN ANY PRODUCT, EXCEPT UNDER AN EXPRESS WRITTEN AGREEMENT WITH BECKMAN INSTRUMENTS, INC.

REV.	E.O.NO.	DATE	BY	CHK
AE	SEE SHT 1			

MAIN 5V SWITCHER

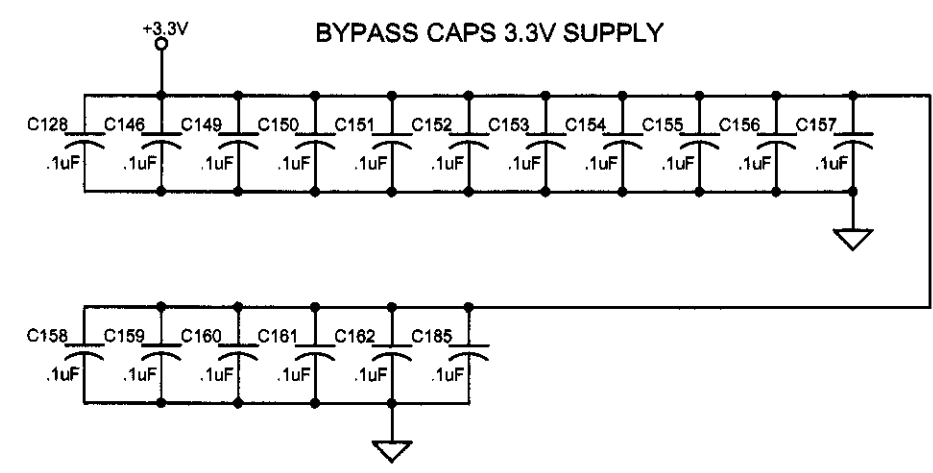
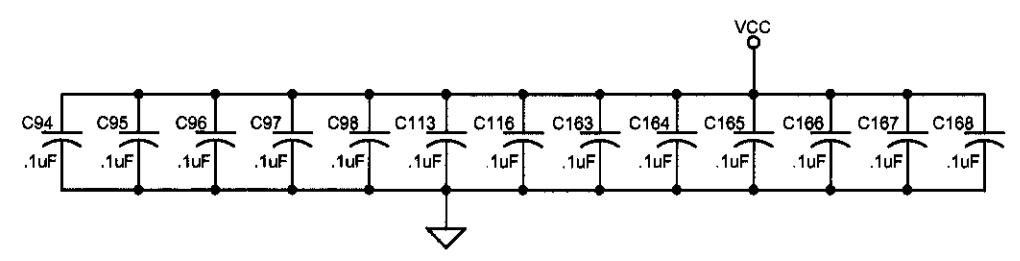
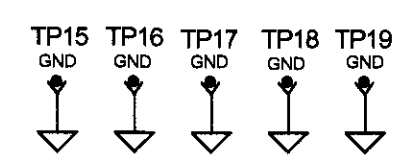
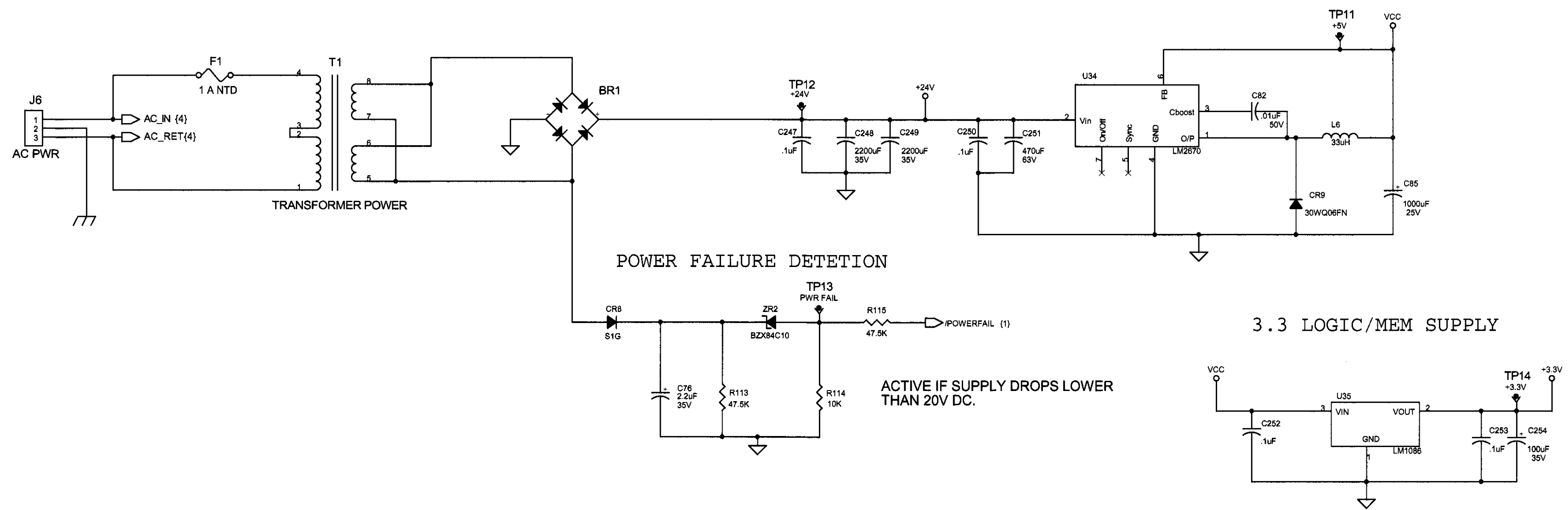

<b>BECKMAN</b>		BECKMAN INSTRUMENTS, INC. SPINCO DIVISION 1050 PAGE MILL ROAD PALO ALTO, CA 94304	
<b>C</b> SIZE	CODE IDENT NO.	DWG NO.	
	<b>07978</b>	<b>392961-01</b>	
SCALE	1st USE	SHT 7 OF 7	

C 392961-01

THIS DOCUMENT CONTAINS PROPRIETARY INFORMATION OF BECKMAN INSTRUMENTS, INC. AND IS TENDERED SUBJECT TO THE CONDITIONS THAT THE INFORMATION (A) BE RETAINED IN CONFIDENCE, (B) NOT BE REPRODUCED OR COPIED IN WHOLE OR IN PART AND (C) NOT BE USED OR INCORPORATED IN ANY PRODUCT, EXCEPT UNDER AN EXPRESS WRITTEN AGREEMENT WITH BECKMAN INSTRUMENTS, INC.

REV.	E.O.NO.	DATE	BY	CHK
01				
AA		9/23/03	JW	
AB		11/7/03	JW	
AC	42179	6/2/04	JW	<i>u.b.</i>

$G = V_{ref}/0.504$   
Voltage read x 205.73 = Vbus

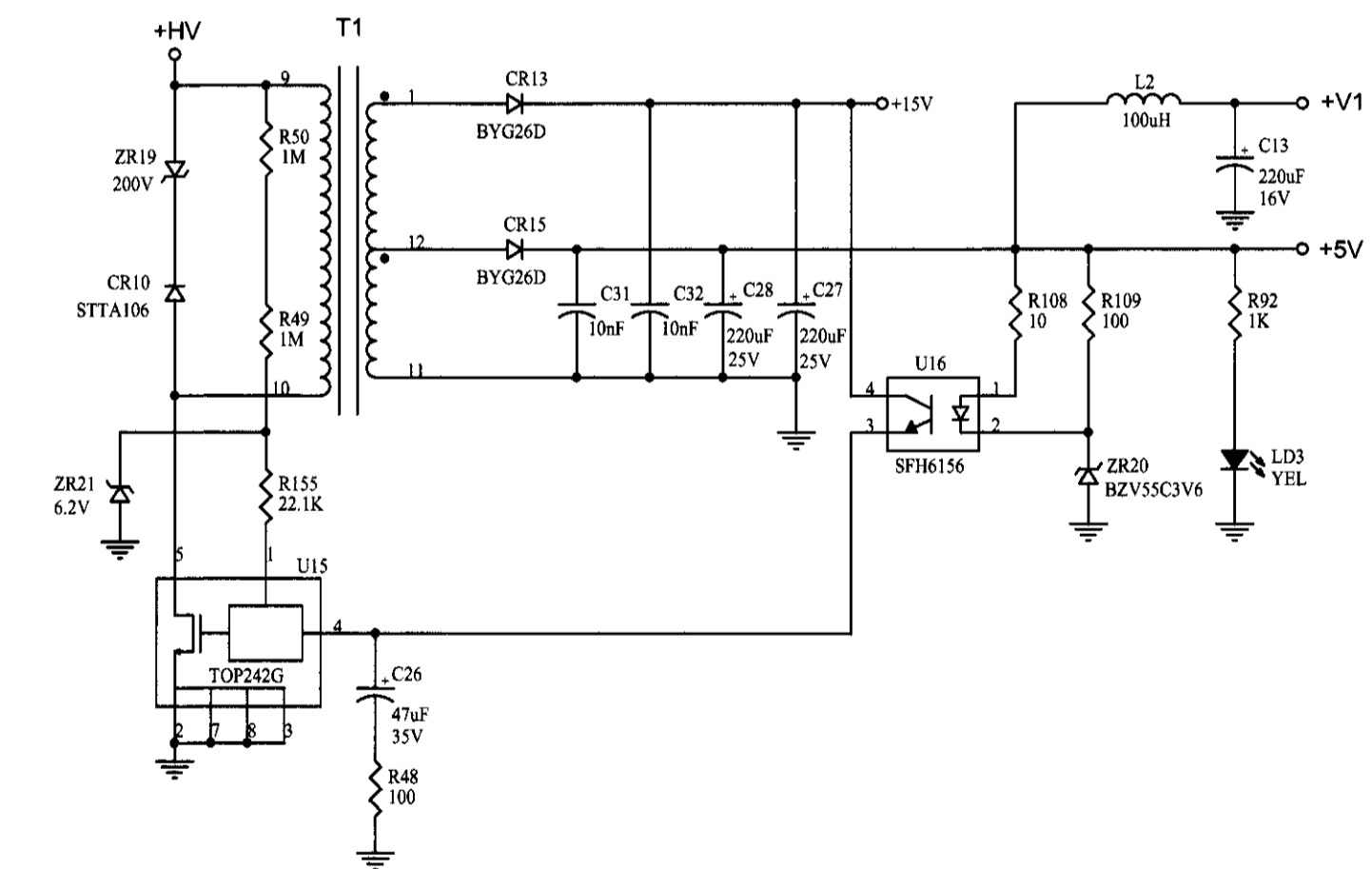
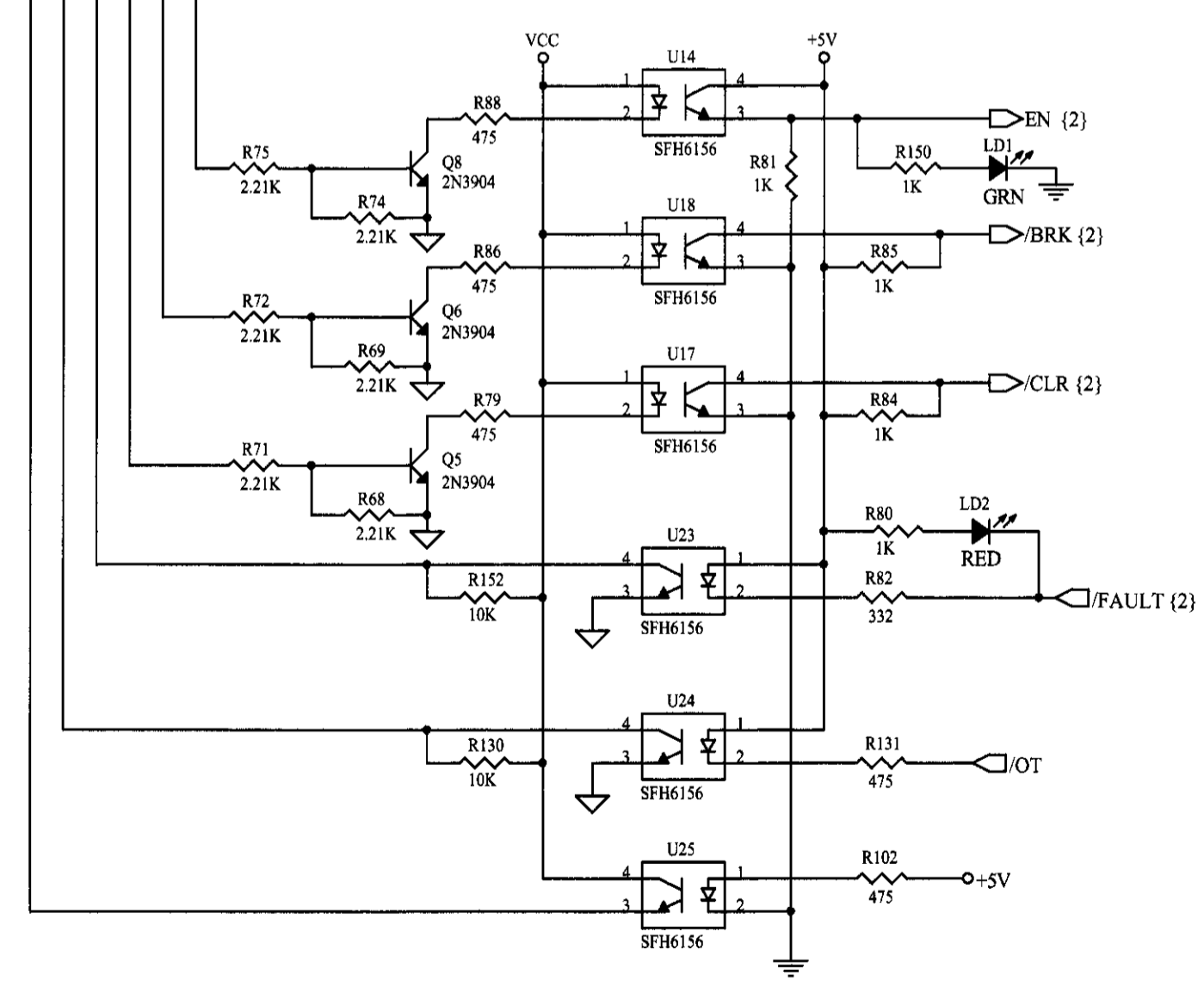
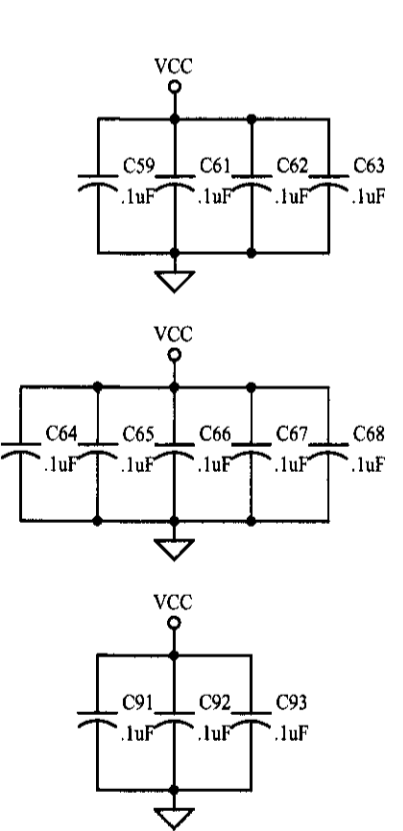
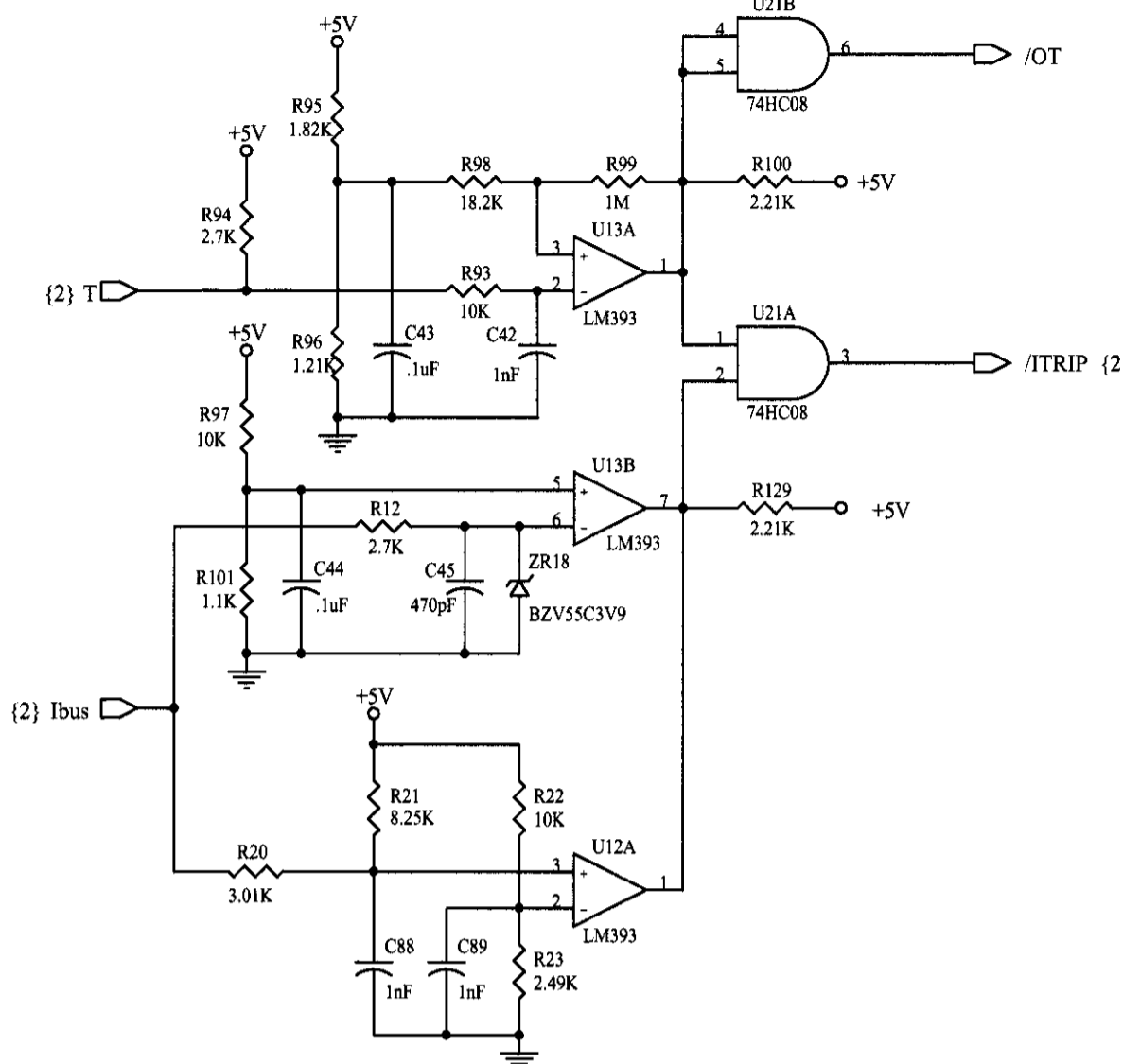
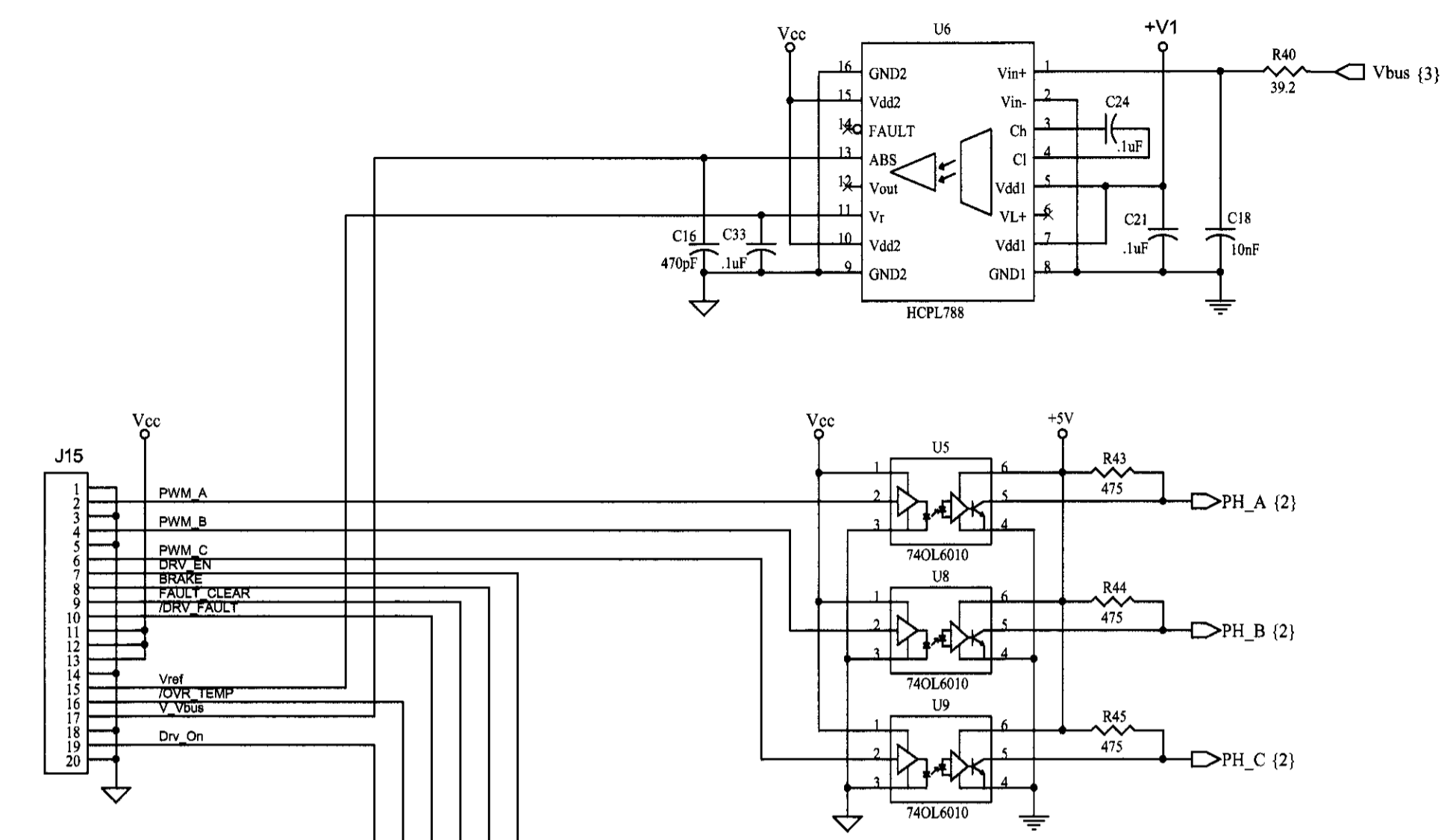

5.  $\perp$  DENOTES NOISY (EARTH DIGITAL) GROUND.
  4. CAPACITOR VALUES ARE IN MICROFARADS.
  3. RESISTOR VALUES ARE IN OHMS.
  2. BOARD ASSEMBLY IS 392449.
  1. REF OVERALL SCHEMATIC 392450-00.
- NOTES: (UNLESS OTHERWISE SPECIFIED)

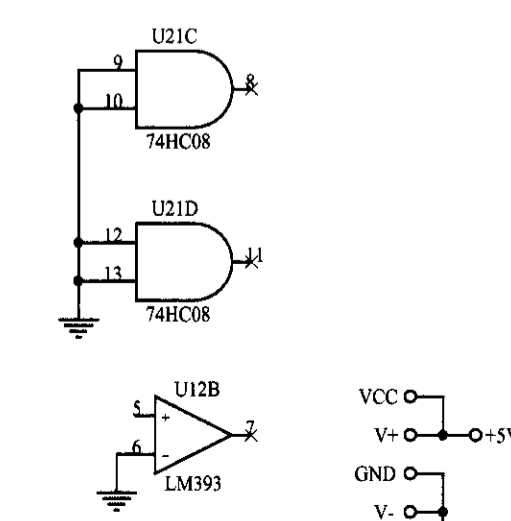

ITEM	QTY	PART NO	DESCRIPTION
BY	DATE	BECKMAN	
DR DALE FRESE	9/23/03	BECKMAN INSTRUMENTS, INC. SPINCO DIVISION 1050 PAGE MILL ROAD PALO ALTO, CA 94304	
CHK		TITLE	
DSGN		SCHEMATIC -	
ENGR		MOTOR DRIVER	
C	CODE IDENT NO.	DWG NO.	
SIZE	07978	392450-02	
MOD	ALLERGA X-12R	SCALE NONE	1st USE
			SHT 1 OF 3

392450-02

THIS DOCUMENT CONTAINS PROPRIETARY INFORMATION OF BECKMAN INSTRUMENTS, INC. AND IS TENDERED SUBJECT TO THE CONDITIONS THAT THE INFORMATION (A) BE RETAINED IN CONFIDENCE, (B) NOT BE REPRODUCED OR COPIED IN WHOLE OR IN PART AND (C) NOT BE USED OR INCORPORATED IN ANY PRODUCT, EXCEPT UNDER AN EXPRESS WRITTEN AGREEMENT WITH BECKMAN INSTRUMENTS, INC.

REV.	E.O.NO.	DATE	BY	CHK
AC	SEE SHT 1			

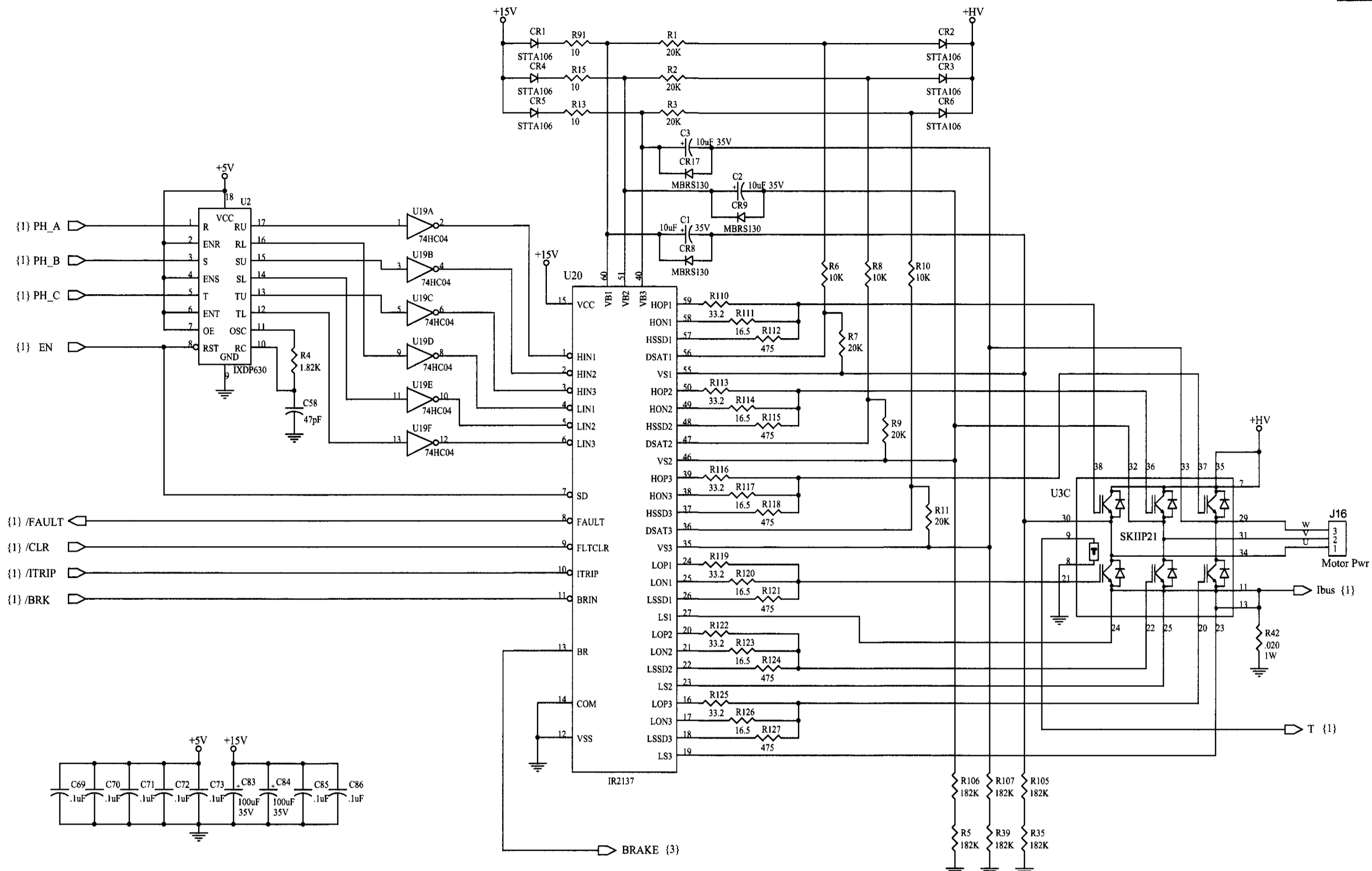

392450-02

<b>BECKMAN</b>		BECKMAN INSTRUMENTS, INC. SPINCO DIVISION 1050 PAGE MILL ROAD PALO ALTO, CA 94304	
<b>C</b> SIZE	CODE IDENT NO. <b>07978</b>	DWG NO. <b>392450-02</b>	
SCALE	1st USE	SHT 2 OF 3	

THIS DOCUMENT CONTAINS PROPRIETARY INFORMATION OF BECKMAN INSTRUMENTS, INC. AND IS TENDERED SUBJECT TO THE CONDITIONS THAT THE INFORMATION (A) BE RETAINED IN CONFIDENCE, (B) NOT BE REPRODUCED OR COPIED IN WHOLE OR IN PART AND (C) NOT BE USED OR INCORPORATED IN ANY PRODUCT, EXCEPT UNDER AN EXPRESS WRITTEN AGREEMENT WITH BECKMAN INSTRUMENTS, INC.

REV.	E.O.NO.	DATE	BY	CHK
AC		SEE SHT 1		

$$I_{pk} = (V_r / R_{138}) * (R_{142} / R_{149})$$

$$V_{ov} = 5.1 * (R_{132} / R_{135} + 1)$$

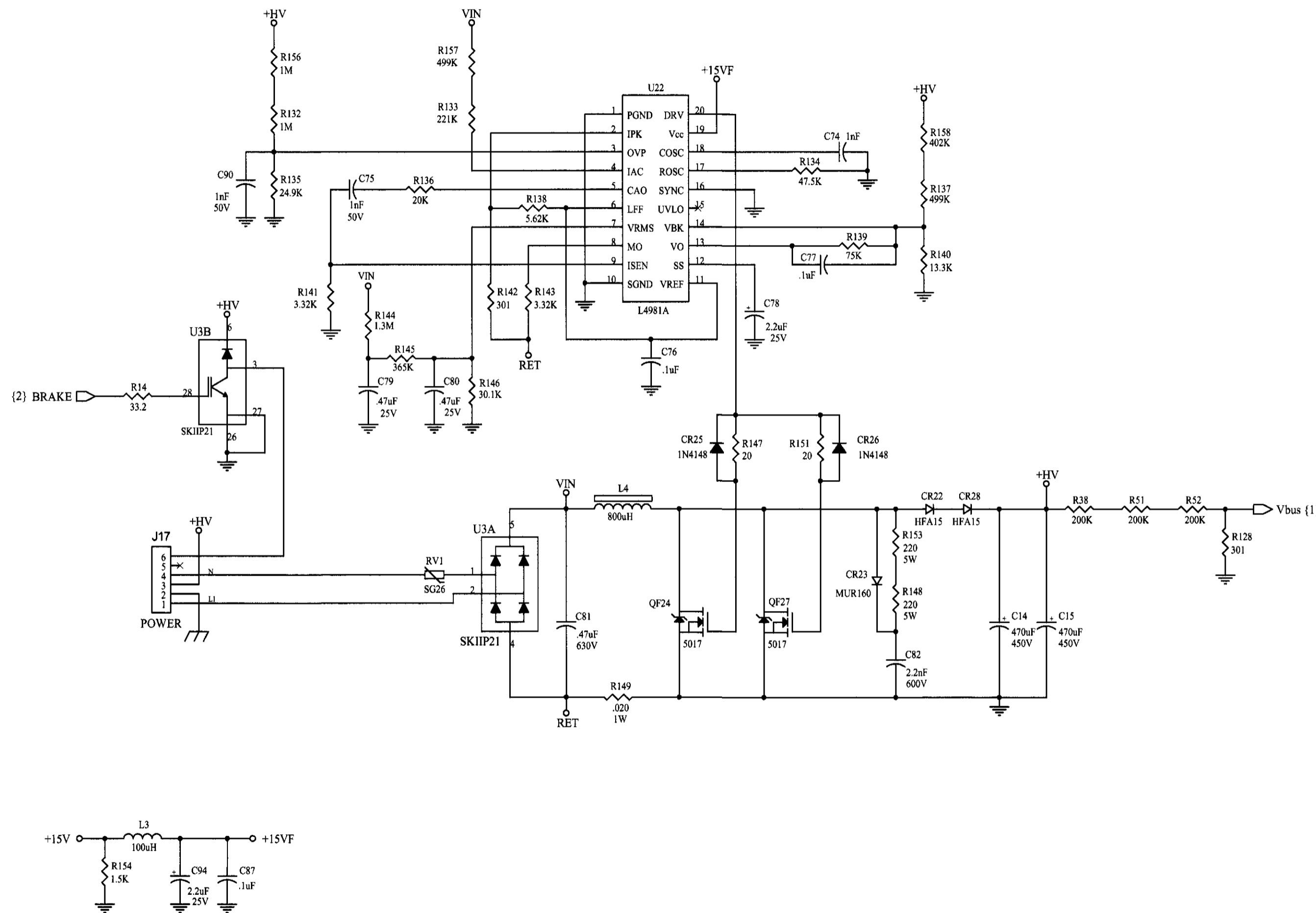

392450-02

<b>BECKMAN</b>		BECKMAN INSTRUMENTS, INC. SPINCO DIVISION 1050 PAGE MILL ROAD PALO ALTO, CA 94304	
C SIZE	CODE IDENT NO. <b>07978</b>	DWG NO. <b>392450-02</b>	
SCALE	1st USE	SHT 3 OF 3	

THIS DOCUMENT CONTAINS PROPRIETARY INFORMATION OF BECKMAN INSTRUMENTS, INC. AND IS TENDERED SUBJECT TO THE CONDITIONS THAT THE INFORMATION (A) BE RETAINED IN CONFIDENCE, (B) NOT BE REPRODUCED OR COPIED IN WHOLE OR IN PART AND (C) NOT BE USED OR INCORPORATED IN ANY PRODUCT, EXCEPT UNDER AN EXPRESS WRITTEN AGREEMENT WITH BECKMAN INSTRUMENTS, INC.

CHG.	E.O.NO.	DATE	BY	CHK
AA				
AB	42118	3/23/04	CWB	SC
AC	42147	4/9/04	CWB	SC
AD	42181	5/25/04	CWB	JW
AE	42198	6/10/04	CWB	JW

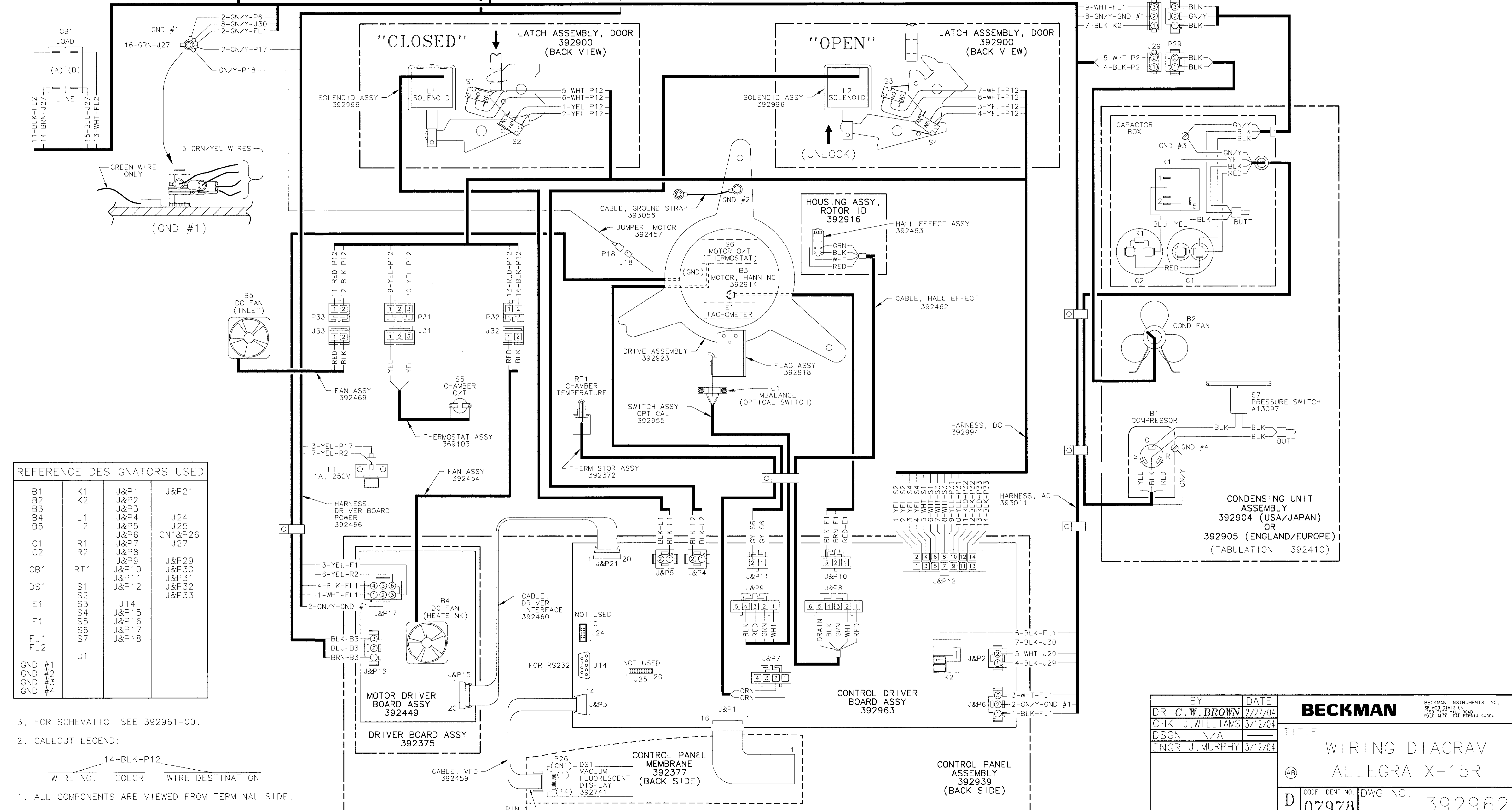
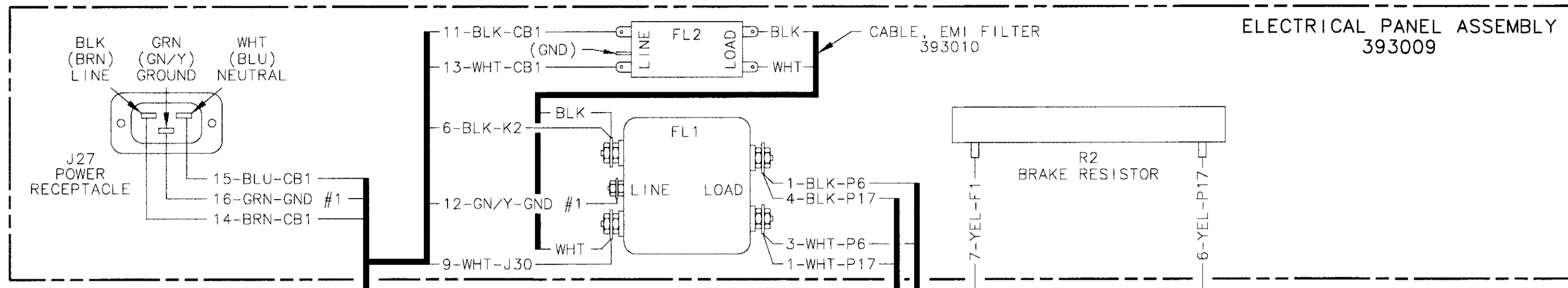

REFERENCE DESIGNATORS USED

B1	K1	J&P1	J&P21
B2	K2	J&P2	
B3		J&P3	
B4	L1	J&P4	J24
B5	L2	J&P5	J25
		J&P6	CN1&P26
C1	R1	J&P7	J27
C2	R2	J&P8	
		J&P9	J&P29
CB1	RT1	J&P10	J&P30
		J&P11	J&P31
DS1	S1	J&P12	J&P32
			J&P33
E1	S2	J14	
	S3	J&P15	
F1	S4	J&P16	
	S5	J&P17	
FL1	S6	J&P18	
FL2	S7		
	U1		
GND #1			
GND #2			
GND #3			
GND #4			

3. FOR SCHEMATIC SEE 392961-00.  
 2. CALLOUT LEGEND:  
 WIRE NO.    COLOR    WIRE DESTINATION

1. ALL COMPONENTS ARE VIEWED FROM TERMINAL SIDE.

NOTES: (UNLESS OTHERWISE SPECIFIED)

BY DR C.W. BROWN	DATE 2/27/04	<b>BECKMAN</b> SPRINGS DIVISION 1055 PAGE MILL ROAD PALO ALTO, CALIFORNIA 94304
CHK J. WILLIAMS	DATE 3/12/04	
ENGR J. MURPHY	DATE 3/12/04	
TITLE WIRING DIAGRAM ALLEGRA X-15R		D SIZE 07978
MOD ALLEGRA X-15R		
SCALE NONE		1st USE 392930 SHEET 1 OF 1

D 392962 DWG. NO.